

Robert J. Huston, *Chairman*
R. B. "Ralph" Marquez, *Commissioner*
Kathleen Hartnett White, *Commissioner*



TEXAS COMMISSION ON ENVIRONMENTAL QUALITY

Protecting Texas by Reducing and Preventing Pollution

November 6, 2002

Mr. Robert L. Worth, Jr.
R.L. Worth and Associates
4040 Broadway, Suite 552
San Antonio, TX, 78216

Re: Edwards Aquifer, Comal County
NAME OF PROJECT: Heritage Business Park, 1650 and 1672 Independence Drive; New Braunfels, Texas
TYPE OF PLAN: Request for Modification of a Water Pollution Abatement Plan (WPAP); 30 Texas Administrative Code (TAC) Chapter 213 Edwards Aquifer
Edwards Aquifer Protection Program File No. 1814.00, Regulated Entity Reference Number RN102750627 and Edwards Aquifer Protection Program File No. 1605.00, Regulated Entity Reference Number RN102751252

Dear Mr. Worth:

The Texas Commission on Environmental Quality (TCEQ) has completed its review of the request for modification of the approved WPAP for the referenced project submitted to the San Antonio Regional Office by Cara C. Tackett, P.E. on behalf of R.L. Worth & Associates on August 21, 2002. As presented to the TCEQ, the Temporary and Permanent Best Management Practices (BMPs) and construction plans were prepared by a Texas Licensed Professional Engineer to be in general compliance with the requirements of 30 TAC Chapter 213. These planning materials were sealed, signed, and dated by a Texas Licensed Professional Engineer. Therefore, based on the engineer's concurrence of compliance, the planning materials for construction of the proposed project and pollution abatement measures are hereby approved subject to applicable state rules and the conditions in this letter. The applicant or a person affected may file with the chief clerk a motion for reconsideration of the executive director's final action on this Edwards Aquifer protection plan. A motion for reconsideration must be filed no later than 20 days after the date of this approval letter. *This approval expires two (2) years from the date of this letter unless, prior to the expiration date, more than 10 percent of the construction has commenced on the project or an extension of time has been requested.*

PROJECT DESCRIPTION

The sites were previously approved by letters dated May 8, 2002 (Heritage Business Park 1814.00 WPAP), and February 2, 2001 (Oak Run Commercial Unit 9 1605.00 WPAP). As presented, the proposed modifications to the referenced Water Pollution Abatement Plans will consist of revisions to sedimentation/filtration Basin A of the Heritage Business Park WPAP and Basin A of the Oak Run Commercial Unit 9 WPAP (now referred to as Basin B-1). The revisions are reported to be necessary due to design changes required for the stormwater detention basin adjacent to both water quality basins.

The modifications to both sites are summarized in the plan as follows:

- Runoff from Watershed B-2 (2.68 acres) within the Heritage site is redirected to Basin B-1 within the Oak Run site. This requires the storage volume to Basin B-1 to be increased because the watershed draining to the basin has increased by 2.68 acres. This also results in the storage volume of Basin A to decrease because of the reduction in watershed size.
- Overflow from Basin B-1 is discharged to the creek instead of being sent to the detention basin.
- Upgradient runoff is directed around the Heritage Business Park site and directly into the detention basin. This upgradient runoff is detained in lieu of detaining the on-site runoff.

According to the plan, there is no change in population, water usage, or generation of wastewater as a result of this modification. No additional naturally occurring geologic features are reported to be impacted by this modification.

PERMANENT POLLUTION ABATEMENT MEASURES

Two previously approved sedimentation/filtration basins designed using the TNRCC technical guidance document, *Complying with the Edwards Aquifer Rules: Technical Guidance on Best Management Practices* (June 1999) will be modified and constructed to treat storm water runoff. Modified Basin A is designed to provide treatment for 5.03 acres of the site with a capture volume of 27,480 cubic feet and a sand filter area of 2,720 square feet. Basin B-1, as modified, is designed to provide treatment for 12.33 acres of the site with a capture volume of 62,398 cubic feet and a sand filter area of 7,264 square feet. The approved measures have been presented to meet the required 80 percent removal of the increased load in total suspended solids caused by the project.

SPECIAL CONDITIONS

- I. This modification is also subject to all applicable Special and Standard Conditions listed in the WPAP approval letters of May 8, 2002 (Heritage Business Park WPAP), and February 2, 2001 (Oak Run Commercial Unit 9 WPAP).
- II. All existing permanent pollution abatement measures shall remain operational during modification construction activities and all proposed permanent measures must be operational prior to commencement of commercial activities on the respective site.
- III. The sedimentation/filtration basins are designed in accordance with the TNRCC technical guidance document, *Complying with the Edwards Aquifer Rules: Technical Guidance on Best Management Practices* (June 1999). The basins will incorporate sedimentation and filtration as described above.
- IV. All sediment and or media removed from the partial sedimentation/filtration basins during maintenance activities shall be properly disposed of according to 30 TAC 330 or 30 TAC 335 as applicable.

Mr. Robert L. Worth, Jr.
November 6, 2002
Page 3

If you have any questions or require additional information, please contact Lynn M. Bumgardner of the Edwards Aquifer Protection Program of the San Antonio Regional Office at 210/403-4023.

Sincerely,

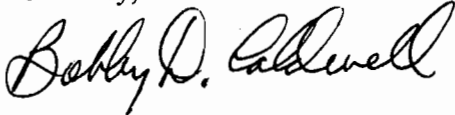

for Margaret Hoffman
Executive Director
Texas Commission on Environmental Quality

MH/LMB/eg

Enclosure: Deed Recordation Affidavit, Form TCEQ-0625
Change in Responsibility for Maintenance or Permanent BMPs-Form TCEQ-10263

cc: Ms. Cara C. Tackett, Pape-Dawson Engineers, Inc.
Mr. Michael Short, P.E., City of New Braunfels
Mr. Tom Hornseth, Comal County
Mr. Greg Ellis, Edwards Aquifer Authority
TCEQ Central Records, Building F, MC 212



HERITAGE BUSINESS PARK

Water Pollution Abatement Plan Modification

August 2002

PAPE-DAWSON ENGINEERS, INC.

2002 AUG 21 PM 4: 09

PAPE-DAWSON ENGINEERS, INC.
SAN ANTONIO
REGION



August 21, 2002

Richard Garcia
TNRCC Region 13
14250 Judson Road
San Antonio, Texas 78233-4480

Re: Heritage Business Park
Water Pollution Abatement Plan Modification
TNRCC Project No. 1814.00 and 1605.00

Dear Mr. Garcia:

Please find attached one (1) original and three (3) copies of the Heritage Business Park Water Pollution Abatement Plan Modification. This Water Pollution Abatement Plan Modification has been prepared to be consistent with the Texas Natural Resource Conservation Commission (30 TAC 213) and current policies for development over the Edwards Aquifer Recharge Zone.

This Water Pollution Abatement Plan Modification applies to an approximate 28.56-acre site identified as the limits of the project. Please review the plan information for the items it is intended to address, and, if acceptable, provide a written approval of the plan in order that construction may begin at the earliest opportunity.

Appropriate review fees (\$5,000) and fee application are included. If you have any questions regarding this information, please call our office.

Very truly yours,
Pape-Dawson Engineers, Inc.

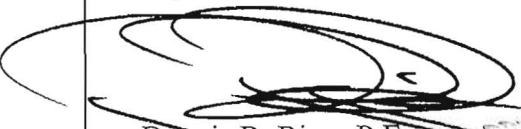
Dennis R. Rion, P.E.
Vice President

Attachments

5329\02\Word\Report\020708a1



Cara C. Tackett, P.E.
Project Manager

PAPE-DAWSON ENGINEERS, INC.

555 East Ramsey | San Antonio, Texas 78216 | Phone: 210.375.9000 | Fax: 210.375.9010 | info@pape-dawson.com

HERITAGE BUSINESS PARK WATER POLLUTION ABATEMENT PLAN MODIFICATION

EXECUTIVE SUMMARY

This application addresses modifications to the Heritage Business Park WPAP originally approved by the TNRCC on May 8, 2002 (TNRCC File No. 1814.00) and the Oak Run Commercial Unit 9 WPAP originally approved by the TNRCC on February 2, 2001 (TNRCC File No. 1605.00). A copy of each approval letter is included in Appendix A. This modification applies to revisions to sedimentation/filtration Basin A of the Heritage Business Park WPAP and Basin A of the Oak Run Commercial Unit 9 WPAP (referred to as Basin "B-1" in this report). Revisions to the sedimentation/filtration basins became necessary when design changes were required for the stormwater detention basin adjacent to both water quality basins.

PROJECT DESCRIPTION

This modification addresses changes made to the two sedimentation/filtration basins resulting from design changes to the stormwater detention basin located on the Heritage Business Park site and approved for construction in the Oak Run Commercial Unit-9 WPAP. The Heritage Business Park and the Oak Run Commercial Unit-9 sites are located within the City of New Braunfels in Comal County, Texas. Both sites were submitted in separate WPAPs but are being developed by the same applicant/responsible party.

The City of New Braunfels requires detention of stormwater runoff from commercial sites to provide for discharge at pre-development rates. The original design concept for stormwater management provided for the capture of all on-site stormwater runoff from the Oak Run and Heritage sites and the diversion of upgradient stormwater runoff around the sites. Due to construction and other design constraints, the concept of managing on-site and off-site stormwater runoff had to be re-evaluated. The original stormwater design concept and subsequent revisions can be summarized as follows:

Original Concept:

- Runoff from each site is directed to water quality basins within their respective site.
- Both water quality basins overflow to one common detention basin.
- Upgradient runoff is directed around both sites and the detention basin then discharged directly to the creek at the rear of the sites.

New Concept :

- Runoff from Watershed B-2 (2.68 acres) within the Heritage site is redirected to Basin B-1 within the Oak Run site. This requires the storage volume of Basin B-1 to be increased because the watershed draining to the basin has increased by 2.68 acres. This also results in the storage volume of Basin B to decrease because of the reduction in watershed size.
- Overflow from Basin B-1 is discharged to the creek instead of being sent to the detention basin.

HERITAGE BUSINESS PARK

WATER POLLUTION ABATEMENT PLAN MODIFICATION

- Upgradient runoff is directed around the Heritage Business Park site and directly into the detention basin. This upgradient runoff is detained in lieu of detaining the on-site runoff.

The attached exhibits show the original and modified watersheds and drainage patterns. Also attached is a summary of design criteria for both water quality basins as approved under the original WPAPs and as proposed in this WPAP Modification.

No change in population, water usage, or generation of wastewater will occur as a result of this modification. Land use and site plans remain the same for both commercial sites. Construction on the Oak Run site, Basin B-1, and the detention basin has been completed. Construction of the Heritage site is currently underway. The volume of Basin B-1 will be increased while the basin remains operational in order to continue to provide treatment to the existing Oak Run site. The underdrain system and sand filter will not be altered. The volume of Basin B-1 will be increased by changing the side slopes on three sides of the basin from 3:1 earthen slopes to 1:1 concrete slopes as shown on Exhibit 5.

Both sedimentation/filtration basins have been designed to remove 80% of the increased Total Suspended Solids (TSS) for the entire watershed area it is intended to treat in accordance with TNRCC's Technical Guidance Manual RG-348 (1999).

GEOLOGY

No additional naturally occurring geologic features will be impacted by this modification. Geologic assessments were submitted with the approved WPAPs for Heritage Business Park site under TNRCC File No. 1814.00 and for Oak Run Commercial Unit 9 under TNRCC File No. 1605.00.

POLLUTION ABATEMENT

During Construction

The methodology for pollution prevention of on-site or upgradient stormwater during construction will include the following:

1. Silt fencing located downgradient of the limits of construction and rock berms where appropriate will be used for temporary erosion and sedimentation control during construction.
2. A construction staging area will be put in place for material stockpiles, machinery storage, and machinery maintenance.
3. Stabilized construction entrance/exit(s) will be put in place to reduce the dispersion of

HERITAGE BUSINESS PARK
WATER POLLUTION ABATEMENT PLAN MODIFICATION

sediment from the site and to aid in accessibility to the site.

4. Concrete truck washout pit(s) will be put in place to prevent contamination of stormwater around the site.
5. The excavation for the sedimentation/filtration basins will be used as temporary sediment traps.

After Construction

1. Silt fencing and rock berms where appropriate will be maintained until the parking, utilities, and drainage improvements are completed, and adequate vegetation is established to minimize runoff.
2. Stormwater from within the development will be discharged to two-sedimentation/filtration basins. Each basin has been designed to remove 80% of the increased Total Suspended Solids (TSS) in accordance with TNRCC's Technical Guidance Manual RG-348 (1999).

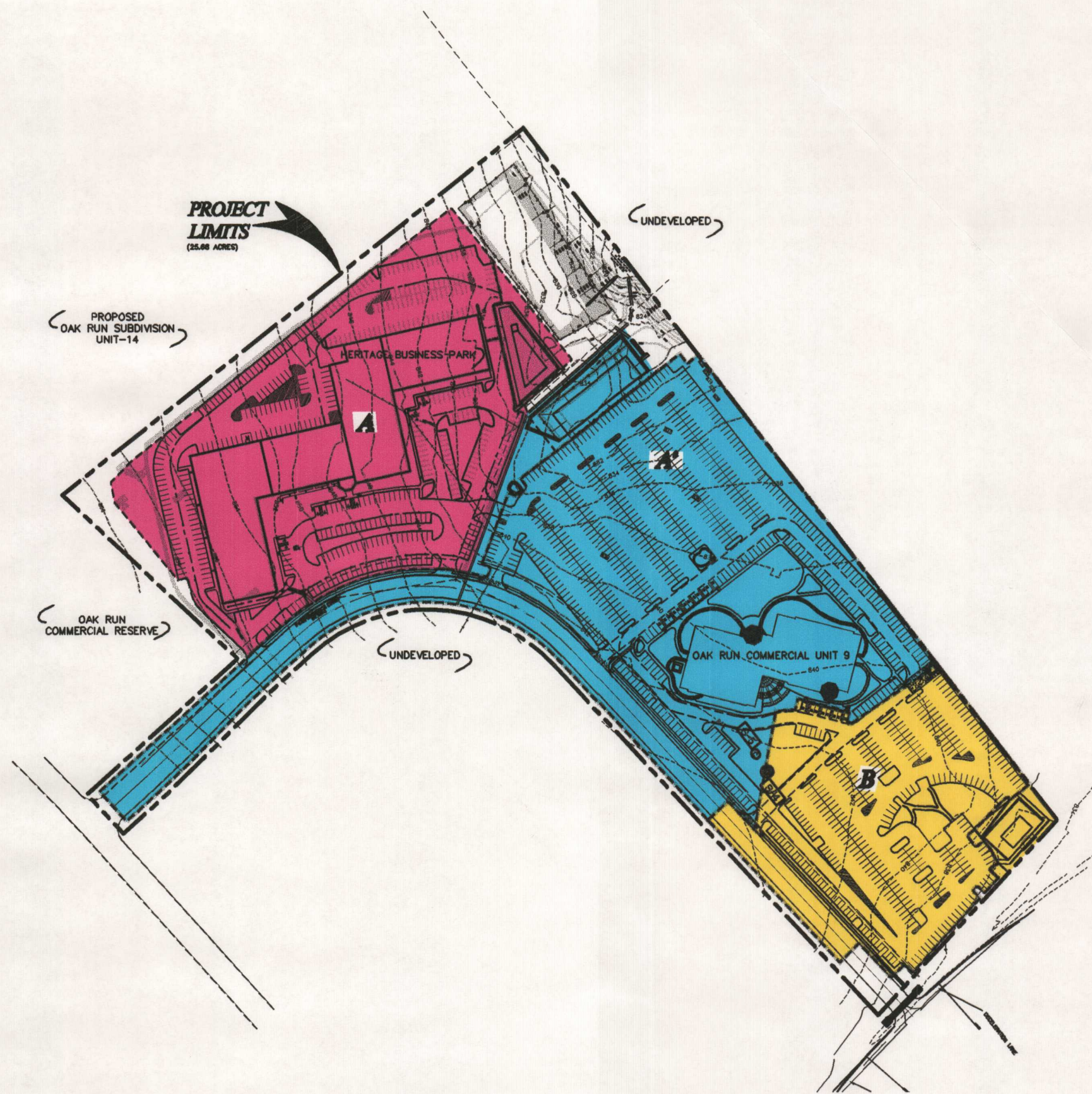

LEGEND	
	EXISTING CONTOURS
	PROJECT LIMITS
	DRAINAGE AREA
	WATERSHED A - HERITAGE PARK THROC FILE# 1814.00
	WATERSHED A' - OAK RUN COMM. V-9 THROC FILE# 11805.00
	WATERSHED B

REVISED

PAPE-DAWSON ENGINEERS
 280 EAST HANLEY | SAN ANTONIO TEXAS 78205 | PHONE 512-341-1111
 FAX 512-341-1112

HERITAGE BUSINESS PARK
 ORIGINAL WATERSHED AREAS
 1 OF 1

JOB NO. 5329.02
 DATE AUGUST 2002
 DRAWER JD
 CHECKED DR, DWG, RLS
 SHEET 1 OF 1

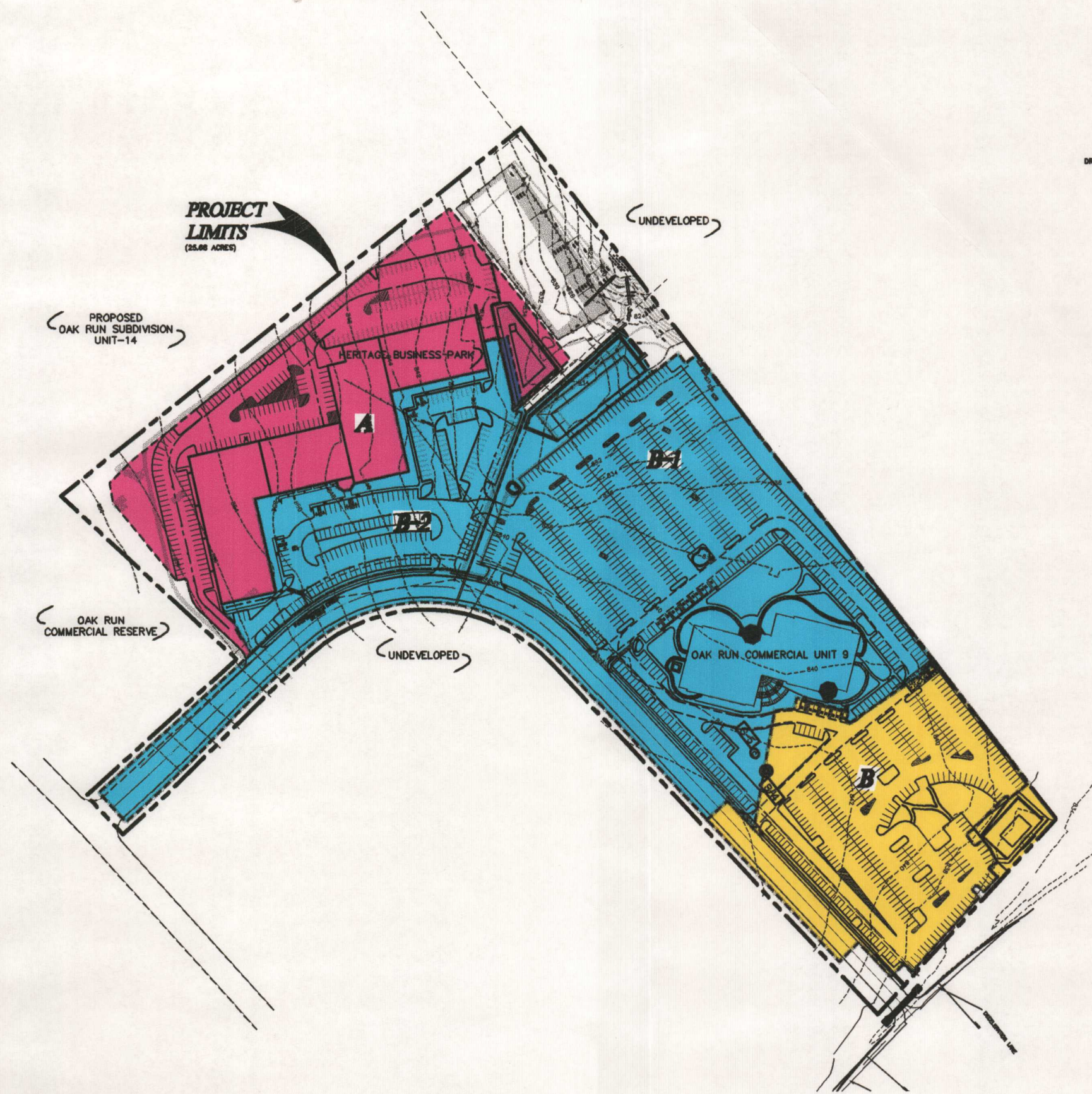

LEGEND	
	EXISTING CONTOURS
	PROJECT LIMITS
	DRAINAGE AREA
	WATERSHED A - HERITAGE BUSINESS PARK
	WATERSHED B-1 HERITAGE BUSINESS PARK
	WATERSHED B-2 OAK RUN COMM UNIT 9
	WATERSHED B OAK RUN COMM UNIT 9

REVISED

PAPE-DAWSON ENGINEERS
 500 EAST HANLEY | SAN ANTONIO TEXAS 78216 | PHONE 512.343.8800
 FAX 512.343.8800

**HERITAGE BUSINESS PARK
 REVISED WATERSHED AREAS
 1 OF 1**

JOB NO. 5329.02
 DATE AUGUST 2002
 DRAWN JD
 CHECKED DR THOMAS RLS
 SHEET 1 OF 1

GENERAL INFORMATION FORM
FOR REGULATED ACTIVITIES ON THE
EDWARDS AQUIFER RECHARGE AND TRANSITION ZONES
AND RELATING TO 30 TAC §213.4(b) & §213.5(b)(2)(A), (B)
EFFECTIVE JUNE 1, 1999

PROJECT NAME: Heritage Business Park

COUNTY: Comal STREAM BASIN: Blieders Creek

EDWARDS AQUIFER: RECHARGE ZONE
 TRANSITION ZONE

PLAN TYPE: WPAP AST EXCEPTION
 SCS UST MODIFICATION

APPLICANT INFORMATION

1. Applicant:

Contact Person: Robert L. Worth, Jr.
Entity: R.L. Worth & Associates
Mailing Address: 4040 Broadway, Suite 552
City, State: San Antonio, TX Zip 78216
Telephone: (210) 822-5220 FAX: (210) 822-5224

2. Agent/Representative (If any):

Contact Person: Cara C. Tackett, P.E.
Entity: Pape-Dawson Engineers, Inc.
Mailing Address: 555 E. Ramsey
City, State: San Antonio, Texas Zip: 78216
Telephone: (210) 375-9000 FAX: (210) 375-9020

PROJECT LOCATION

3. Site Address: 1650 (Oak Run Commercial Unit-9); 1672 (Heritage Business Park)
Street: Independence Drive
City: New Braunfels, Texas Zip: 78132

4. This project is inside the city limits of New Braunfels.
 This project is outside the city limits but inside the ETJ (extra-territorial jurisdiction) of _____.
 This project is not located within any city's limits or ETJ.

5. The location of the project site is described below. The description provides sufficient detail and clarity so that the TNRCC's Regional staff can easily locate the project and site boundaries for a field investigation.

From TNRCC's Regional office, head south to IH-35 approximately 1.5 miles. Travel north on IH-35 approximately 15 miles to Loop 337. Proceed north on Loop 337 approximately 3 miles to Hwy. 46. The site lies approximately 0.1 miles from the northwest corner of Loop 337 and Hwy. 46, along Independence Drive.

6. **ATTACHMENT A - ROAD MAP.** A road map showing directions to and the location of the project site is attached at the end of this form **directly behind this sheet.**
7. **ATTACHMENT B - USGS / EDWARDS RECHARGE ZONE MAP.** A copy of the official 7 ½ minute USGS Quadrangle Map (Scale: 1" = 2000') of the Edwards Recharge Zone is attached **behind this sheet.** The map(s) should clearly show:
- Project site.
 - USGS Quadrangle Name(s).
 - Boundaries of the Recharge Zone (and Transition Zone, if applicable).
 - Drainage path from the project to the boundary of the Recharge Zone.

8. Sufficient survey staking is provided on the project to allow TNRCC regional staff to locate the boundaries and alignment of the regulated activities and the geologic or manmade features noted in the Geologic Assessment. **The TNRCC must be able to inspect the project site or the application will be returned.**

9. **ATTACHMENT C - PROJECT DESCRIPTION.** Attached at the end of this form is A detailed narrative description of the proposed project **is provided below:**

This modification addresses changes made to the two sedimentation/filtration basins resulting from design changes to the stormwater detention basin located on the Heritage Business Park site and approved for construction in the Oak Run Commercial Unit-9 WPAP. The Heritage Business Park and the Oak Run Commercial Unit-9 sites are located within the City of New Braunfels in Comal County, Texas. Both sites were submitted in separate WPAPs but are being developed by the same applicant/responsible party.

The City of New Braunfels requires detention of stormwater runoff from commercial sites to provide for discharge at pre-development rates. The original design concept for stormwater management provided for the capture of all on-site stormwater runoff from the Oak Run and Heritage sites and the diversion of upgradient stormwater runoff around the sites. Due to construction and other design constraints, the concept of managing on-site and off-site stormwater runoff had to be re-evaluated. The original stormwater design concept and subsequent revisions can be summarized as follows:

Original Concept:

- ***Runoff from each site is directed to water quality basins within their respective site.***
- ***Both water quality basins overflow to one common detention basin.***

HERITAGE BUSINESS PARK WATER POLLUTION ABATEMENT PLAN

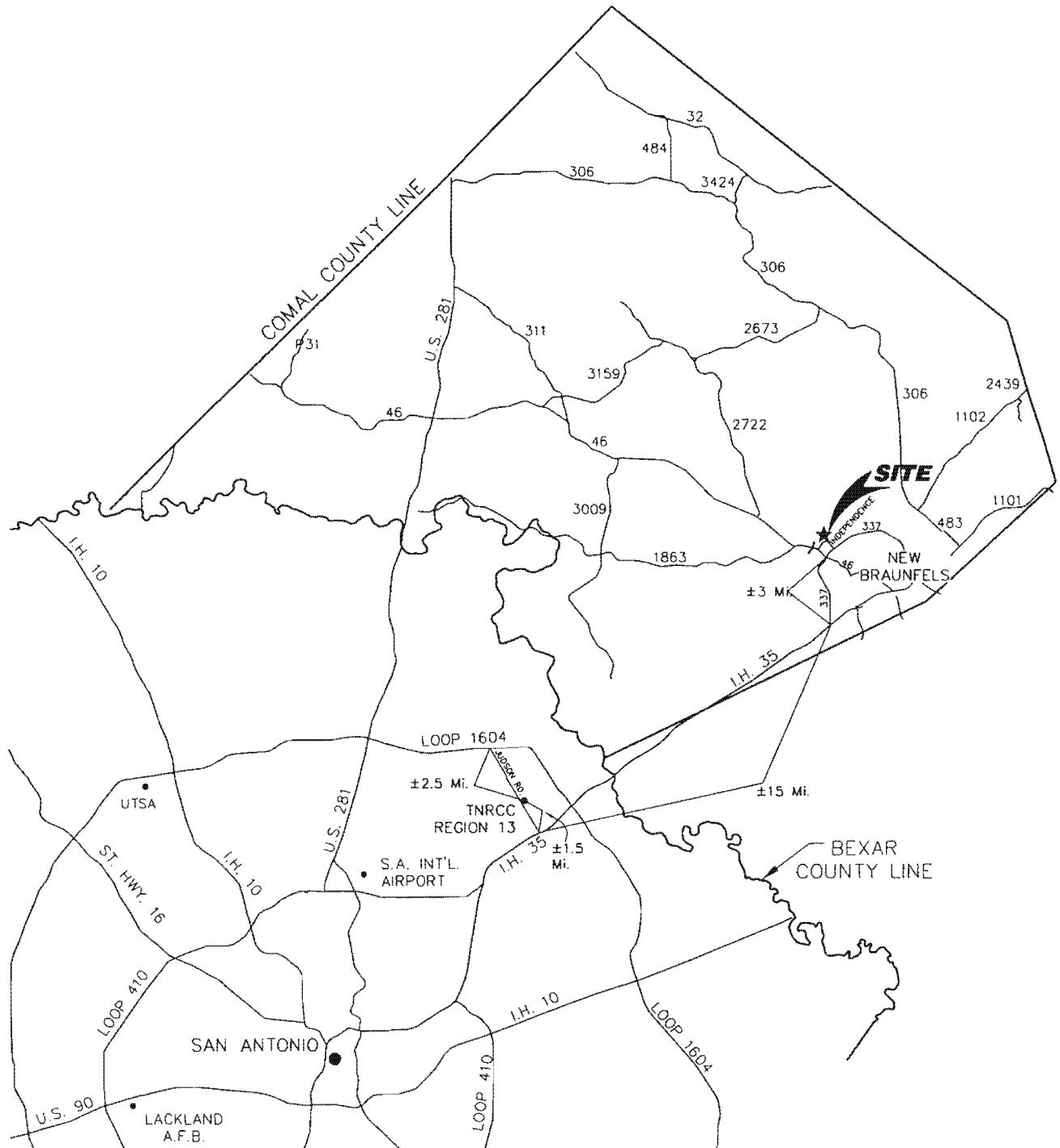

**HERITAGE BUSINESS PARK
WATER POLLUTION ABATEMENT PLAN**

N
SCALE: 1" = 2000'

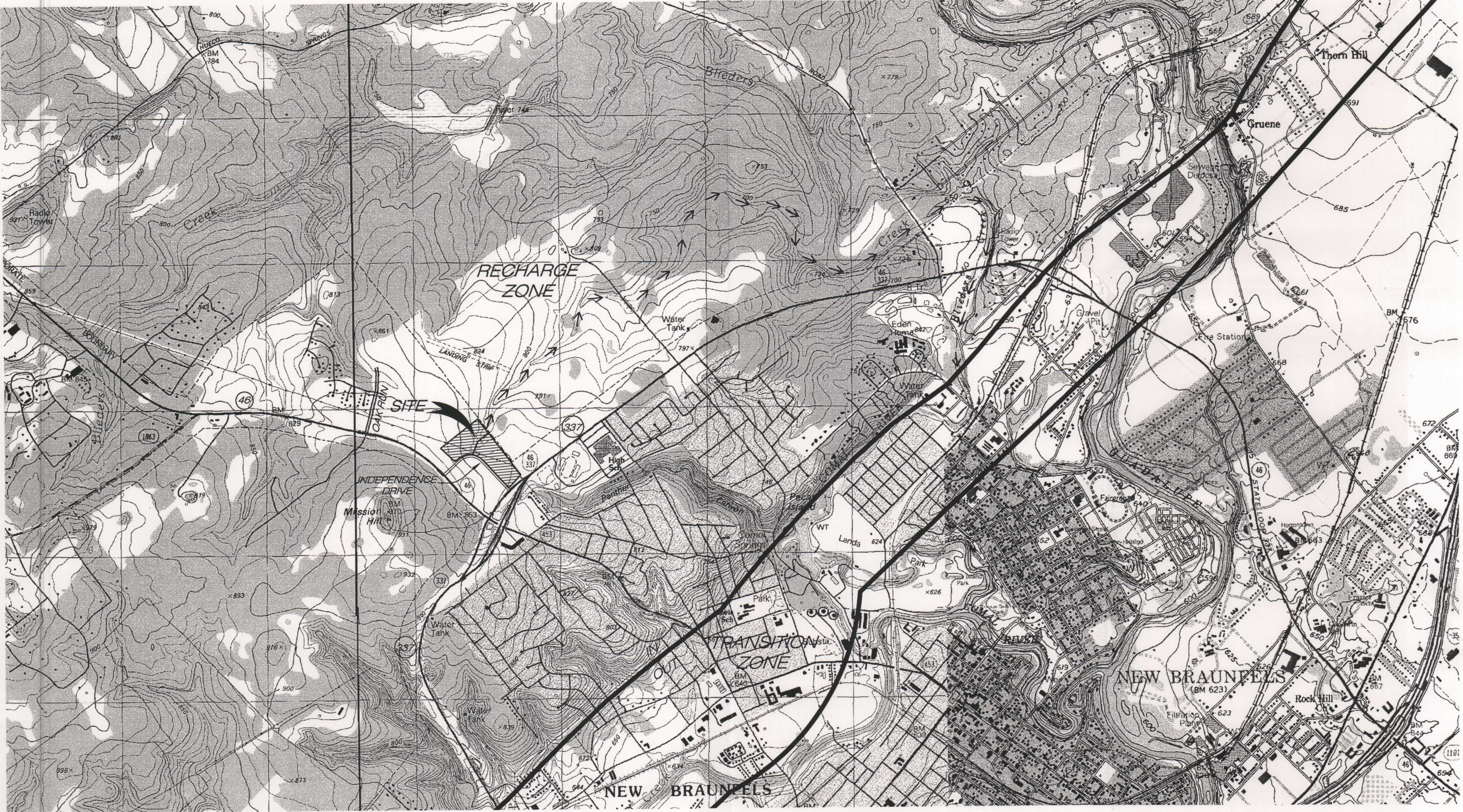

NEW BRAUNFELS WEST TX, QUADRANGLE
→ → → DRAINAGE FLOW
Pape-Dawson Engineers, Inc.

USGS/EDWARDS RECHARGE ZONE MAP
ATTACHMENT B

- *Upgradient runoff is directed around both sites and the detention basin then discharged directly to the creek at the rear of the sites.*

New Concept :

- *Runoff from Watershed B-2 (2.68 acres) within the Heritage site is redirected to Basin B-1 within the Oak Run site. This requires the storage volume of Basin B 1 to be increased because the watershed draining to the basin has increased by 2.68 acres. This also results in the storage volume of Basin B to decrease because of the reduction in watershed size.*
- *Overflow from Basin B-1 is discharged to the creek instead of being sent to the detention basin.*
- *Upgradient runoff is directed around the Heritage Business Park site and directly into the detention basin. This upgradient runoff is detained in lieu of detaining the on-site runoff.*

The attached exhibits show the original and modified watersheds and drainage patterns. Also attached is a summary of design criteria for both water quality basins as approved under the original WPAPs and as proposed in this WPAP Modification.

No change in population, water usage, or generation of wastewater will occur as a result of this modification. Land use and site plans remain the same for both commercial sites. Construction on the Oak Run site, Basin B-1, and the detention basin has been completed. Construction of the Heritage site is currently underway. The volume of Basin B-1 will be increased while the basin remains operational in order to continue to provide treatment to the existing Oak Run site. The underdrain system and sand filter will not be altered. The volume of Basin B-1 will be increased by changing the side slopes on three sides of the basin from 3:1 earthen slopes to 1:1 concrete slopes as shown on Exhibit 5.

Both sedimentation/filtration basins have been designed to remove 80% of the increased Total Suspended Solids (TSS) for the entire watershed area it is intended to treat in accordance with TNRCC's Technical Guidance Manual RG-348 (1999).

10. Existing project site conditions are noted below:

- Existing commercial site
- Existing industrial site
- Existing residential site
- Existing paved and/or unpaved roads
- Undeveloped (Cleared)
- Undeveloped (Undisturbed/Uncleared)
- Other: _____

PROHIBITED ACTIVITIES

11. I am aware that the following activities are prohibited on the **Recharge Zone** and are not proposed for this project:

- (1) waste disposal wells regulated under 30 TAC Chapter 331 of this title (relating to

- (2) new feedlot/concentrated animal feeding operations, as defined in 30 TAC §213.3;
- (3) land disposal of Class I wastes, as defined in 30 TAC §335.1;
- (4) the use of sewage holding tanks as parts of organized collection systems; and
- (5) new municipal solid waste landfill facilities required to meet and comply with Type I standards which are defined in §330.41(b), (c), and (d) of this title (relating to Types of Municipal Solid Waste Facilities).

12. I am aware that the following activities are prohibited on the **Transition Zone** and are not proposed for this project:

- (1) waste disposal wells regulated under 30 TAC Chapter 331 (relating to Underground Injection Control);
- (2) land disposal of Class I wastes, as defined in 30 TAC §335.1; and
- (3) new municipal solid waste landfill facilities required to meet and comply with Type I standards which are defined in §330.41 (b), (c), and (d) of this title.

ADMINISTRATIVE INFORMATION

13. The fee for the plan(s) is based on:

- For a Water Pollution Abatement Plan and Modifications, the total acreage of the site where regulated activities will occur.
- For an Organized Sewage Collection System Plans and Modifications, the total linear footage of all collection system lines.
- For a UST Facility Plan or an AST Facility Plan, the total number of tanks or piping systems.
- A Contributing Zone Plan.
- A request for an exception to any substantive portion of the regulations related to the protection of water quality.
- A request for an extension to a previously approved plan.

14. Application fees are due and payable at the time the application is filed. If the correct fee is not submitted, the TNRCC is not required to consider the application until the correct fee is submitted. Both the fee and the Edwards Aquifer Fee Form have been sent to the Commission's:

- TNRCC cashier
- Austin Regional Office (for projects in Hays, Travis, and Williamson Counties)
- San Antonio Regional Office (for projects in Bexar, Comal, Kinney, Medina, and Uvalde Counties)

15. Submit one (1) original and three (3) copies of the completed application to the appropriate regional office for distribution by the TNRCC to the local municipality or county, groundwater conservation districts, and the TNRCC's Central Office.

16. No person shall commence any regulated activity until the Edwards Aquifer Protection Plan(s) for the activity has been filed with and approved by the executive director.
 No person shall commence any regulated activity until the Contributing Zone Plan for the activity has been filed with the executive director.

To the best of my knowledge, the responses to this form accurately reflect all information requested concerning the proposed regulated activities and methods to protect the Edwards Aquifer. This **GENERAL INFORMATION FORM** is hereby submitted for TNRCC review. The application was prepared by:

Pape-Dawson Engineers, Inc.

By: Cara C. Tackett, P.E.

Print Name of Applicant/Owner/Agent

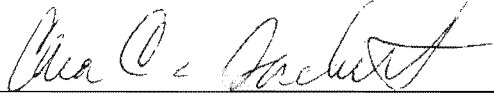

Signature of Applicant/Owner/Agent



Date

GEOLOGIC ASSESSMENT

NO ADDITIONAL NATURALLY OCCURRING GEOLOGIC FEATURES WILL BE IMPACTED BY THIS MODIFICATION. NO GEOLOGIC ASSESSMENT HAS BEEN INCLUDED WITH THIS MODIFICATION. REFER TO THE HERITAGE BUSINESS PARK WPAP APPROVED MAY 8, 2002, TNRCC FILE NO. 1814.00, AND THE OAK RUN COMMERCIAL UNIT 9 WPAP APPROVED FEBRUARY 2, 2001, TNRCC FILE NO. 1605.00.

MODIFICATION OF A PREVIOUSLY APPROVED PLAN
FOR REGULATED ACTIVITIES
ON THE EDWARDS AQUIFER RECHARGE ZONE AND TRANSITION ZONE
AND RELATING TO 30 TAC §213.4(j), EFFECTIVE JUNE 1, 1999

1. Project Name: Heritage Business Park
2. Original Project Name: Heritage Business Park and Oak Run Commercial Unit 9
3. **ATTACHMENT A - Original Approval Letter.** A copy of the original approval letter and copies of any letters approving modifications are found at the end of this form **in Appendix A.**
4. A modification of a previously approved plan is requested for: (INDICATE ALL THAT APPLY)
 - physical or operational modification of any water pollution abatement structure(s), including but not limited to ponds, dams, berms, sewage treatment plants, and diversionary structures;
 - change in the nature or character of the regulated activity from that which was originally approved or a change which would significantly impact the ability of the plan to prevent pollution of the Edwards Aquifer;
 - development of land previously identified as undeveloped in the original water pollution abatement plan;
 - physical modification of the approved organized sewage collection system;
 - physical modification of the approved underground storage tank system;
 - physical modification of the approved aboveground storage tank system.
5. **ATTACHMENT B - Narrative of Proposed Modification.** A narrative description of the nature of each proposed modification is provided ~~at the end of this form~~ **directly below.**

This application addresses modifications to the Heritage Business Park WPAP originally approved by the TNRCC on May 8, 2002 (TNRCC File No. 1814.00) and the Oak Run Commercial Unit 9 WPAP originally approved by the TNRCC on February 2, 2001 (TNRCC File No. 1605.00). A copy of each approval letter is included in Appendix A. This modification applies to revisions to sedimentation/filtration Basin A of the Heritage Business Park and Basin A of the Oak Run Commercial Unit 9 development (referred to as Basin B-1 in this modification).

This modification addresses changes made to the two sedimentation/filtration basins resulting from design changes to the stormwater detention basin located on the Heritage Business Park site and approved for construction in the Oak Run Commercial Unit-9 WPAP. The Heritage Business Park and the Oak Run Unit9 sites are located within the City of New Braunfels in Comal County, Texas. Both sites were submitted in separate WPAPs but are being developed by the same applicant/responsible party.

Due to revisions to stormwater runoff and detention, runoff from approximately 2.68 acres originally directed toward Basin A in the Heritage site will be directed towards Basin B-1 within the Oak Run site. This revision will increase the required volume of

Basin B-1 from 37,253 cubic feet (CF) to 55,823 CF and the required sand surface area from 3,991 square feet (SF) to 5,981 SF. As originally constructed, the sand surface area provided for Basin B-1 was 7,264 SF and therefore no adjustment to the sand will be required under this modification, only the water quality storage volume will be adjusted. The revision will decrease the required volume of Basin A from 34,897 CF to 25,995 CF and the required sand surface area from 2,908 SF to 2,437 SF. Both sedimentation/filtration basins have been designed to remove 80% of the increased Total Suspended Solids (TSS) for the entire watershed area it is intended to treat in accordance with TNRCC's Technical Guidance Manual RG-348 (1999).

No change in population, water usage, or generation of wastewater will occur as a result of this modification. Land use and site plans remain the same for both commercial sites. Construction on the Oak Run site, Basin B-1, and the detention basin has been completed.

6. Original Project:

Heritage Business Park (TNRCC File No. 1814.00)

Type:	WPAP <input checked="" type="checkbox"/> SCS <input type="checkbox"/> UST <input type="checkbox"/> AST <input type="checkbox"/>
Size:	<u>10.4</u> acres
Population:	<u>660</u>
Wastewater Volume:	<u>13,200</u> gal/day
Sewer Pipe:	<u>N/A</u> linear ft
Hydrocarbon Storage:	<u>N/A</u> # of tanks
Impervious Cover:	<u>63.0</u> %

Oak Run Commercial Unit-9 (TNRCC File No. 1605.00)

Type:	WPAP <input checked="" type="checkbox"/> SCS <input type="checkbox"/> UST <input type="checkbox"/> AST <input type="checkbox"/>
Size:	<u>18.16</u> acres
Population:	<u>1,050</u>
Wastewater Volume:	<u>21,000</u> gal/day
Sewer Pipe:	<u>N/A</u> linear ft
Hydrocarbon Storage:	<u>N/A</u> # of tanks
Impervious Cover:	<u>58.38</u> %

7. Proposed Modification:

Type:	WPAP <input checked="" type="checkbox"/> SCS <input type="checkbox"/> UST <input type="checkbox"/> AST <input type="checkbox"/>
Size:	<u>28.56 (combined)</u> acres
Population:	<u>1,710 (combined)</u>
Wastewater Volume:	<u>34,200 (combined)</u> gal/day
Sewer Pipe:	<u>N/A</u> linear ft
Hydrocarbon Storage:	<u>N/A</u> # of tanks
Impervious Cover:	<u>60.05 (combined)</u> %

8. **ATTACHMENT C - Site Plan.** A Site Plan showing the existing conditions of the site, the location of proposed modification(s), and, as applicable, geologic or man-made features, temporary erosion and sedimentation controls, and permanent BMPs is found at the end of this form.

9. One (1) original and three (3) copies of a completed application has been provided.

To the best of my knowledge, the responses to this form accurately reflect all information requested concerning the proposed regulated activities and methods to protect the Edwards Aquifer. This request for a **MODIFICATION TO A PREVIOUSLY APPROVED PLAN** is hereby submitted for TNRCC review and executive director approval. The request was prepared by:

Pape-Dawson Engineers, Inc.

By: Cara C. Tackett, P.E.

Print Name of Applicant/Owner/Agent

Cara C. Tackett
Signature of Applicant/Owner/Agent

08/21/02
Date

**HERITAGE BUSINESS PARK
WATER POLLUTION ABATEMENT PLAN MODIFICATION**

APPENDIX A

Robert J. Huston, *Chairman*
R. B. "Ralph" Marquez, *Commissioner*
Kathleen Hartnett White, *Commissioner*
Jeffrey A. Saitas, *Executive Director*

TEXAS NATURAL RESOURCE CONSERVATION COMMISSION

Protecting Texas by Reducing and Preventing Pollution

May 8, 2002

Mr. Robert L. Worth, Jr.
R. L. Worth & Associates
4040 Broadway, Suite 552
San Antonio, TX 78216

Re: Edwards Aquifer, Comal County
NAME OF PROJECT: Heritage Business Park; Located on the northwest side of Independence Drive; New Braunfels, Texas
TYPE OF PLAN: Request for Approval of a Water Pollution Abatement Plan (WPAP); 30 Texas Administrative Code (TAC) Chapter 213 Edwards Aquifer
Edwards Aquifer Protection Program File No. 1814.00

Dear Mr. Worth:

The Texas Natural Resource Conservation Commission (TNRCC) has completed its review of the WPAP application for the referenced project submitted to the San Antonio Regional Office by Cara C. Tackett, P.E., of Pape-Dawson Engineers, Inc. on behalf of R. L. Worth & Associates on February 13, 2002. As presented to the TNRCC, the Temporary and Permanent Best Management Practices (BMPs) and construction plans were prepared by a Texas Licensed Professional Engineer to be in general compliance with the requirements of 30 TAC Chapter 213. These planning materials were sealed, signed, and dated by a Texas Licensed Professional Engineer. Therefore, based on the engineer's concurrence of compliance, the planning materials for construction of the proposed project and pollution abatement measures are hereby approved subject to applicable state rules and the conditions in this letter. The applicant or a person affected may file with the chief clerk a motion for reconsideration of the executive director's final action on this Edwards Aquifer protection plan. A motion for reconsideration must be filed no later than 20 days after the date of this approval letter. *This approval expires two (2) years from the date of this letter unless, prior to the expiration date, more than 10 percent of the construction has commenced on the project or an extension of time has been requested.*

PROJECT DESCRIPTION

The proposed commercial project will have an area of approximately 10.4 acres. It will include the construction of a single story, 90,380 square foot office building and associated parking. The impervious cover will be 6.55 acres (63.0 percent). Project wastewater will be disposed of by conveyance to the existing New Braunfels Utilities Water Recycling Center owned by the New Braunfels Utilities.

PAPE-DAWSON
ENGINEERS, INC.
RECEIVED

REPLY TO: REGION 13 • 14250 JUDSON RD. • SAN ANTONIO, TEXAS 78233-4480 • 210/490-3096 • FAX 210/545-4329

P O Box 13087 • Austin, Texas 78711-3087 • 512/239-1000 • Internet address: www.tnrcc.state.tx.us

Mr. Robert L. Worth
Page 2
May 8, 2002

PERMANENT POLLUTION ABATEMENT MEASURES

A modified partial sedimentation filtration basin designed using the TNRCC technical guidance document, *Complying with the Edwards Aquifer Rules: Technical Guidance on Best Management Practices* (June 1999) will be constructed to treat storm water runoff. The basin is designed to provide treatment for 7.71 acres (6.55 acres of the impervious cover) with capture volume of 35,485 cubic feet and a sand filter area of 4,125 square feet. The approved measures have been presented to meet the required 80 percent removal of the increased load in total suspended solids caused by the project.

GEOLOGY

According to the geologic assessment included with the application, three geologic features were identified on the site. The San Antonio Regional Office site inspection of April 24, 2002, revealed that regulated activities have occurred on the site.

SPECIAL CONDITIONS

- I. All permanent pollution abatement measures shall be operational prior to use of any of the facilities.
- II. All sediment and or media removed from the sedimentation/filtration basins during maintenance activities shall be properly disposed of according to 30 TAC 330 or 30 TAC 335 as applicable.
- III. A sediment depth marker, as described in *Complying with the Edwards Aquifer Rules: Technical Guidance on Best Management Practices* (June 1999), must be installed in the sedimentation/filtration basin.
- IV. During the April 24, 2002, site assessment investigation of the project site, cleared and disturbed areas were observed. This construction was conducted without the prior approval of the water pollution abatement plan as required by Commission rules (30 TAC Chapter 213). Therefore, the applicant is hereby advised that the after-the-fact approval of the development, as provided by this letter, shall not absolve the applicant of any prior violations of Commission rules related to this project, and shall not necessarily preclude the Commission from pursuing appropriate enforcement actions and administrative penalties associated with such violations, as provided in 30 TAC §213.10 of Commission rules.

STANDARD CONDITIONS

1. Pursuant to §26.136 of the Texas Water Code, any violations of the requirements in 30 TAC Chapter 213 may result in administrative penalties.

Prior to Commencement of Construction:

2. Within 60 days of receiving written approval of an Edwards Aquifer protection plan, the applicant must submit to the San Antonio Regional Office, proof of recordation of notice in the county deed records, with the volume and page number(s) of the county deed records of the county in which the

Mr. Robert L. Worth

Page 3

May 8, 2002

property is located. A description of the property boundaries shall be included in the deed recordation in the county deed records. A suggested form (Deed Recordation Affidavit, TNRCC-0625) that you may use to deed record the approved WPAP is enclosed.

3. All contractors conducting regulated activities at the referenced project location shall be provided a copy of this notice of approval. At least one complete copy of the approved WPAP and this notice of approval shall be maintained at the project location until all regulated activities are completed.
4. Modification to the activities described in the referenced WPAP application following the date of approval may require the submittal of a plan to modify this approval, including the payment of appropriate fees and all information necessary for its review and approval prior to initiating construction of the modifications.
5. The applicant must provide written notification of intent to commence construction, replacement, or rehabilitation of the referenced project. Notification must be submitted to the San Antonio Regional Office no later than 48 hours prior to commencement of the regulated activity. Written notification must include the date on which the regulated activity will commence, the name of the approved plan and file number for the regulated activity, and the name of the prime contractor with the name and telephone number of the contact person. The executive director will use the notification to determine if the approved plan is eligible for an extension.
6. Temporary erosion and sedimentation (E&S) controls, i.e., silt fences, rock berms, stabilized construction entrances, or other controls described in the approved WPAP, must be installed prior to construction and maintained during construction. Temporary E&S controls may be removed when vegetation is established and the construction area is stabilized. If a water quality pond is proposed, it shall be used as a sedimentation basin during construction. The TNRCC may monitor stormwater discharges from the site to evaluate the adequacy of temporary E&S control measures. Additional controls may be necessary if excessive solids are being discharged from the site.
7. All borings with depths greater than or equal to 20 feet must be plugged with non-shrink grout from the bottom of the hole to within three (3) feet of the surface. The remainder of the hole must be backfilled with cuttings from the boring. All borings less than 20 feet must be backfilled with cuttings from the boring. All borings must be backfilled or plugged within four (4) days of completion of the drilling operation. Voids may be filled with gravel.

During Construction:

8. During the course of regulated activities related to this project, the applicant or agent shall comply with all applicable provisions of 30 TAC Chapter 213, Edwards Aquifer. The applicant shall remain responsible for the provisions and conditions of this approval until such responsibility is legally transferred to another person or entity.
9. If any sensitive feature (caves, solution cavities, sink holes, etc.) is discovered during construction, all regulated activities near the feature must be suspended immediately. The applicant or his agent must immediately notify the San Antonio Regional Office of the discovery of the feature. Regulated

Mr. Robert L. Worth

Page 4

May 8, 2002

activities near the feature may not proceed until the executive director has reviewed and approved the methods proposed to protect the feature and the aquifer from potentially adverse impacts to water quality. The plan must be sealed, signed, and dated by a Texas Licensed Professional Engineer.

10. No wells exist on the site. All water wells, including injection, dewatering, and monitoring wells must be in compliance with the requirements of the Texas Department of Licensing and Regulation under Title 16 TAC Chapter 76 (relating to Water Well Drillers and Pump Installers) and all other locally applicable rules, as appropriate.
11. If sediment escapes the construction site, the sediment must be removed at a frequency sufficient to minimize offsite impacts to water quality (e.g., fugitive sediment in street being washed into surface streams or sensitive features by the next rain). Sediment must be removed from sediment traps or sedimentation ponds not later than when design capacity has been reduced by 50 percent. Litter, construction debris, and construction chemicals shall be prevented from becoming stormwater discharge pollutants.
12. The following records shall be maintained and made available to the executive director upon request: the dates when major grading activities occur, the dates when construction activities temporarily or permanently cease on a portion of the site, and the dates when stabilization measures are initiated.
13. Stabilization measures shall be initiated as soon as practicable in portions of the site where construction activities have temporarily or permanently ceased, and construction activities will not resume within 21 days. When the initiation of stabilization measures by the 14th day is precluded by weather conditions, stabilization measures shall be initiated as soon as practicable.

After Completion of Construction:

14. A Texas Licensed Professional Engineer must certify in writing that the permanent BMPs or measures were constructed as designed. The certification letter must be submitted to the San Antonio Regional Office within 30 days of site completion.
15. The applicant shall be responsible for maintaining the permanent BMPs after construction until such time as the maintenance obligation is either assumed in writing by another entity having ownership or control of the property (such as without limitation, an owner's association, a new property owner or lessee, a district, or municipality) or the ownership of the property is transferred to the entity. The regulated entity shall then be responsible for maintenance until another entity assumes such obligations in writing or ownership is transferred. A copy of the transfer of responsibility must be filed with the executive director through the San Antonio Regional Office within 30 days of the transfer. A copy of the transfer form (TNRCC-10263) is enclosed.
16. Upon legal transfer of this property, the new owner(s) is required to comply with all terms of the approved Edwards Aquifer protection plan. If the new owner intends to commence any new regulated activity on the site, a new Edwards Aquifer protection plan that specifically addresses the new activity must be submitted to the executive director. Approval of the plan for the new regulated activity by the executive director is required prior to commencement of the new regulated activity.

Mr. Robert L. Worth
Page 5
May 8, 2002

17. An Edwards Aquifer protection plan approval or extension will expire and no extension will be granted if more than 50 percent of the total construction has not been completed within ten years from the initial approval of a plan. A new Edwards Aquifer protection plan must be submitted to the San Antonio Regional Office with the appropriate fees for review and approval by the executive director prior to commencing any additional regulated activities.
18. At project locations where construction is initiated and abandoned, or not completed, the site shall be returned to a condition such that the aquifer is protected from potential contamination.

If you have any questions or require additional information, please contact Lynn M. Bumgardner of the Edwards Aquifer Protection Program of the San Antonio Regional Office at (210) 403-4023.

Sincerely,



for Jeffrey A. Saitas, P.E.
Executive Director
Texas Natural Resource Conservation Commission

JAS/LMB/eg

Enclosure: Deed Recordation Affidavit, Form TNRCC-0625
Change in Responsibility for Maintenance on Permanent BMPs-Form TNRCC-10263

cc: Ms. Cara C. Tackett, P.E., Pape-Dawson Engineers, Inc.
Mr. Michael Short, P.E., City of New Braunfels
Mr. Tom Hornsath, Comal County
Mr. Greg Ellis, Edwards Aquifer Authority
TNRCC Field Operations

Robert J. Huston, *Chairman*
R. B. "Ralph" Marquez, *Commissioner*
John M. Baker, *Commissioner*
Jeffrey A. Saitas, *Executive Director*



file
5123-04

TEXAS NATURAL RESOURCE CONSERVATION COMMISSION

Protecting Texas by Reducing and Preventing Pollution

February 2, 2001

Mr. Robert L. Worth, Jr.
R. L. Worth & Associates
4040 Broadway, Suite 552
San Antonio, TX 78209

Re: Edwards Aquifer, Comal County
NAME OF PROJECT: Oak Run Commercial Unit 9; Located on Loop 337 approximately 700 feet north of State Hwy 46; New Braunfels, Texas
TYPE OF PLAN: Request for Approval of a Water Pollution Abatement Plan (WPAP); 30 Texas Administrative Code (TAC) Chapter 213 Edwards Aquifer
Edwards Aquifer Protection Program File No. 1605.00

Dear Mr. Worth:

The Texas Natural Resource Conservation Commission (TNRCC) has completed its review of the WPAP application for the referenced project submitted to the San Antonio Regional Office by Cara C. Tackett of Pape-Dawson Engineers on behalf of R. L. Worth & Associates on November 17, 2000. As presented to the TNRCC, the Temporary and Permanent Best Management Practices (BMPs) and construction plans were prepared by a Texas Licensed Professional Engineer to be in general compliance with the requirements of 30 TAC Chapter 213. These planning materials were sealed, signed, and dated by a Texas Licensed Professional Engineer. Therefore, based on the engineer's concurrence of compliance, the planning materials for construction of the proposed project and pollution abatement measures are hereby approved subject to applicable state rules and the conditions in this letter. The applicant or a person affected may file with the chief clerk a motion for reconsideration of the executive director's final action on this Edwards Aquifer protection plan. A motion for reconsideration must be filed no later than 20 days after the date of this approval letter. *This approval expires two (2) years from the date of this letter unless, prior to the expiration date, more than 10 percent of the construction has commenced on the project or an extension of time has been requested.*

PROJECT DESCRIPTION

The proposed commercial project will have an area of approximately 18.06 acres. It will include the construction of a three-story office building, associated parking, the extension of Oak Spur Drive, a storm water detention basin, and two sedimentation/filtration basins. The impervious cover will be 10.60 acres (58.38 percent). Project wastewater will be disposed of by conveyance to the existing New Braunfels Utilities Water Recycling Center owned by the New Braunfels Utilities.

REPLY TO: REGION 13 • 14250 JUDSON RD. • SAN ANTONIO, TEXAS 78233-4480 • 210/490-3096 • FAX 210/545-4329

P.O. Box 13087 • Austin, Texas 78711-3087 • 512/239-1000 • Internet address: www.tnrcc.state.tx.us

PERMANENT POLLUTION ABATEMENT MEASURES

Two sedimentation filtration basins designed using the TNRCC technical guidance document, *Complying with the Edwards Aquifer Rules: Technical Guidance on Best Management Practices* (June 1999) will be constructed to treat storm water runoff. Basin A is designed to provide treatment for 9.40 acres of the site with a capture volume of 37,695 cubic feet and a sand filter area of 7,264 square feet. Basin B is designed to provide treatment for 3.95 acres of the site with a capture volume of 16,134 cubic feet and a sand filter area of 2,925 square feet. The approved measures have been presented to meet the required 80 percent removal of the increased load in total suspended solids caused by the project.

GEOLOGY

According to the geologic assessment included with the application, six geologic features and one man-made feature were identified on the site. Two of the features were described as "sensitive", three were assessed as "possibly sensitive", and two were identified as "not sensitive". The San Antonio Regional Office site inspection of January 22, 2001, revealed that the site is generally as described by the geologic assessment.

SPECIAL CONDITIONS

- I. All permanent pollution abatement measures shall be operational prior to use of any of the facilities.
- II. All sediment and or media removed from the sedimentation/filtration basins during maintenance activities shall be properly disposed of according to 30 TAC 330 or 30 TAC 335 as applicable.
- III. A sediment depth marker, as described in *Complying with the Edwards Aquifer Rules: Technical Guidance on Best Management Practices* (June 1999), must be installed in each sedimentation/filtration basin.

STANDARD CONDITIONS

1. Pursuant to §26.136 of the Texas Water Code, any violations of the requirements in 30 TAC Chapter 213 may result in administrative penalties.

Prior to Commencement of Construction:

2. Within 60 days of receiving written approval of an Edwards Aquifer protection plan, the applicant must submit to the San Antonio Regional Office, proof of recordation of notice in the county deed records, with the volume and page number(s) of the county deed records of the county in which the property is located. A description of the property boundaries shall be included in the deed recordation in the county deed records. A suggested form (Deed Recordation Affidavit, TNRCC-0625) that you may use to deed record the approved WPAP is enclosed.

Mr. Robert L. Worth, Jr.
Page 3
February 2, 2001

3. All contractors conducting regulated activities at the referenced project location shall be provided a copy of this notice of approval. ~~At least one complete copy of the approved WPAP and this notice of approval shall be maintained at the project location until all regulated activities are completed.~~
4. Modification to the activities described in the referenced WPAP application following the date of approval may require the submittal of a plan to modify this approval, including the payment of appropriate fees and all information necessary for its review and approval prior to initiating construction of the modifications.
5. The applicant must provide written notification of intent to commence construction, replacement, or rehabilitation of the referenced project. Notification must be submitted to the San Antonio Regional Office no later than 48 hours prior to commencement of the regulated activity. Written notification must include the date on which the regulated activity will commence, the name of the approved plan and file number for the regulated activity, and the name of the prime contractor with the name and telephone number of the contact person. The executive director will use the notification to determine if the approved plan is eligible for an extension.
6. Temporary erosion and sedimentation (E&S) controls, i.e., silt fences, rock berms, stabilized construction entrances, or other controls described in the approved WPAP, must be installed prior to construction and maintained during construction. Temporary E&S controls may be removed when vegetation is established and the construction area is stabilized. If a water quality pond is proposed, it shall be used as a sedimentation basin during construction. The TNRCC may monitor stormwater discharges from the site to evaluate the adequacy of temporary E&S control measures. Additional controls may be necessary if excessive solids are being discharged from the site.
7. All borings with depths greater than or equal to 20 feet must be plugged with non-shrink grout from the bottom of the hole to within three (3) feet of the surface. The remainder of the hole must be backfilled with cuttings from the boring. All borings less than 20 feet must be backfilled with cuttings from the boring. All borings must be backfilled or plugged within four (4) days of completion of the drilling operation. Voids may be filled with gravel.

During Construction:

8. During the course of regulated activities related to this project, the applicant or agent shall comply with all applicable provisions of 30 TAC Chapter 213, Edwards Aquifer. The applicant shall remain responsible for the provisions and conditions of this approval until such responsibility is legally transferred to another person or entity.
9. If any sensitive feature (caves, solution cavities, sink holes, etc.) is discovered during construction, all regulated activities near the feature must be suspended immediately. The applicant or his agent must immediately notify the San Antonio Regional Office of the discovery of the feature. Regulated activities near the feature may not proceed until the executive director has reviewed and approved the methods proposed to protect the feature and the aquifer from potentially adverse impacts to water quality. The plan must be sealed, signed, and dated by a Texas Licensed Professional Engineer.

Mr. Robert L. Worth, Jr.

Page 4

February 2, 2001

10. No wells exist on the site. All water wells, including injection, dewatering, and monitoring wells must be in compliance with the requirements of the Texas Department of Licensing and Regulation under Title 16 TAC Chapter 76 (relating to Water Well Drillers and Pump Installers) and all other locally applicable rules, as appropriate.
11. If sediment escapes the construction site, the sediment must be removed at a frequency sufficient to minimize offsite impacts to water quality (e.g., fugitive sediment in street being washed into surface streams or sensitive features by the next rain). Sediment must be removed from sediment traps or sedimentation ponds not later than when design capacity has been reduced by 50 percent. Litter, construction debris, and construction chemicals shall be prevented from becoming stormwater discharge pollutants.
12. The following records shall be maintained and made available to the executive director upon request: the dates when major grading activities occur, the dates when construction activities temporarily or permanently cease on a portion of the site, and the dates when stabilization measures are initiated.
13. Stabilization measures shall be initiated as soon as practicable in portions of the site where construction activities have temporarily or permanently ceased, and construction activities will not resume within 21 days. When the initiation of stabilization measures by the 14th day is precluded by weather conditions, stabilization measures shall be initiated as soon as practicable.

After Completion of Construction:

14. A Texas Licensed Professional Engineer must certify in writing that the permanent BMPs or measures were constructed as designed. The certification letter must be submitted to the San Antonio Regional Office within 30 days of site completion.
15. The applicant shall be responsible for maintaining the permanent BMPs after construction until such time as the maintenance obligation is either assumed in writing by another entity having ownership or control of the property (such as without limitation, an owner's association, a new property owner or lessee, a district, or municipality) or the ownership of the property is transferred to the entity. The regulated entity shall then be responsible for maintenance until another entity assumes such obligations in writing or ownership is transferred. A copy of the transfer of responsibility must be filed with the executive director through the San Antonio Regional Office within 30 days of the transfer. A copy of the transfer form (TNRCC-10263) is enclosed.
16. Upon legal transfer of this property, the new owner(s) is required to comply with all terms of the approved Edwards Aquifer protection plan. If the new owner intends to commence any new regulated activity on the site, a new Edwards Aquifer protection plan that specifically addresses the new activity must be submitted to the executive director. Approval of the plan for the new regulated activity by the executive director is required prior to commencement of the new regulated activity.

Mr. Robert L. Worth, Jr.
Page 5
February 2, 2001

17. An Edwards Aquifer protection plan approval or extension will expire and no extension will be granted if more than 50 percent of the total construction has not been completed within ten years from the initial approval of a plan. A new Edwards Aquifer protection plan must be submitted to the San Antonio Regional Office with the appropriate fees for review and approval by the executive director prior to commencing any additional regulated activities.
18. At project locations where construction is initiated and abandoned, or not completed, the site shall be returned to a condition such that the aquifer is protected from potential contamination.

If you have any questions or require additional information, please contact Lynn M. Bumgardner of the Edwards Aquifer Protection Program of the San Antonio Regional Office at (210) 403-4023.

Sincerely,

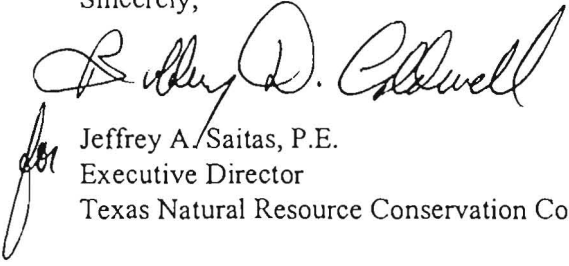

Jeffrey A. Saitas, P.E.
Executive Director
Texas Natural Resource Conservation Commission

JAS/LMB/eg

Enclosure: Deed Recordation Affidavit, Form TNRCC-0625
Change in Responsibility for Maintenance on Permanent BMPs-Form TNRCC-10263

cc: Ms. Cara Tackett, Pape-Dawson Engineers, Inc.
Mr. Harry Bennett, City of New Braunfels
Mr. John Bohuslav, TXDOT San Antonio District
Mr. Tom Hornseth, Comal County
Mr. Greg Ellis, Edwards Aquifer Authority
TNRCC Field Operations, Austin

TEMPORARY STORMWATER SECTION

THERE WILL BE NO CHANGES TO THE TEMPORARY STORMWATER SECTION AS PROVIDED IN THE APPROVED WATER POLLUTION ABATEMENT PLANS; THEREFORE, THIS SECTION HAS NOT BEEN INCLUDED. A COPY OF THE UPDATED TEMPORARY POLLUTION ABATEMENT PLAN CAN BE FOUND AS EXHIBIT 1 IN THE EXHIBITS SECTION OF THIS REPORT.

PERMANENT STORMWATER SECTION

THERE WILL BE NO CHANGES TO THE PERMANENT STORMWATER SECTION AS PROVIDED IN THE APPROVED WATER POLLUTION ABATEMENT PLANS; THEREFORE, THIS SECTION HAS NOT BEEN INCLUDED. A COPY OF THE UPDATED PERMANENT POLLUTION ABATEMENT PLAN WITH THE REVISED BASINS CAN BE FOUND AS EXHIBIT 2 IN THE EXHIBITS SECTION OF THIS REPORT. BASIN DESIGN CALCULATIONS HAVE BEEN INCLUDED IN THE BACK OF THE EXHIBITS SECTION.

AGENT AUTHORIZATION FORM
FOR REQUIRED SIGNATURE
EDWARDS AQUIFER PROTECTION PROGRAM
RELATING TO 30 TAC CHAPTER 213
EFFECTIVE JUNE 1, 1999

I _____ **Robert L. Worth, Jr.**
Print Name

_____ **Manager**
Title - Owner/President/Other

of _____ **R. L. Worth and Associates,**
Corporation/Partnership/Entity Name

have authorized _____ **Pape-Dawson Engineers, Inc.**
Print Name of Agent/Engineer

of _____ **Pape-Dawson Engineers, Inc.**
Print Name of Firm

to represent and act on the behalf of the above named Corporation, Partnership, or Entity for the purpose of preparing and submitting this plan application to the Texas Natural Resource Conservation Commission (TNRCC) for the review and approval consideration of regulated activities.

I also understand that:

1. The applicant is responsible for compliance with 30 Texas Administrative Code Chapter 213 and any condition of the TNRCC's approval letter. The TNRCC is authorized to assess administrative penalties of up to \$10,000 per day per violation.
2. A notarized copy of the Agent Authorization Form must be provided for the person preparing the application, and the forms must accompany the completed application.
3. Application fees are due and payable at the time the application is submitted. The application fee must be sent to the TNRCC cashier or to the appropriate regional office. The application will not be considered until the correct fee is received by the commission.

4. For applicants who are not the property owner, but who have the right to control and possess and control the property, additional authorization is required from the owner.

Applicant's Signature

Date July 11, 2002

THE STATE OF TEXAS §
County of BEXAR §

BEFORE ME, the undersigned authority, on this day personally appeared Robert L. Worth, Jr. known to me to be the person whose name is subscribed to the foregoing instrument, and acknowledged to me that (s)he executed same for the purpose and consideration therein expressed.

GIVEN under my hand and seal of office on this 11th day of July, 2002

NOTARY PUBLIC 

Typed or Printed Name of Notary MARCIA RITTIMAN



MY COMMISSION EXPIRES:

TEXAS NATURAL RESOURCE CONSERVATION COMMISSION
EDWARDS AQUIFER PROTECTION PLAN
APPLICATION FEE FORM

NAME OF PROPOSED PROJECT: Heritage Business Park
 PROJECT LOCATION: Independence Drive, New Braunfels, Texas
 NAME OF APPLICANT: R. L. Worth and Associates
 APPLICANT'S ADDRESS: 4040 Broadway, Suite 552
 CONTACT PERSON: Robert L. Worth, Jr. PHONE (210) 822-5220
 Please Print

AUSTIN REGIONAL OFFICE (3373)

- Hays
- Travis
- Williamson

SAN ANTONIO REGIONAL OFFICE (3362)

- Bexar
- Comal
- Kinney
- Medina
- Uvalde

APPLICATION FEES MUST BE PAID BY CHECK, CERTIFIED CHECK, OR MONEY ORDER, PAYABLE TO THE TEXAS NATURAL RESOURCE CONSERVATION COMMISSION. YOUR CANCELED CHECK WILL SERVE AS YOUR RECEIPT. **THIS FORM MUST BE SUBMITTED WITH YOUR FEE PAYMENT.** THIS PAYMENT IS BEING SUBMITTED TO (CHECK ONE):

SAN ANTONIO REGIONAL OFFICE

- Mailed to TNRCC:
 TNRCC - Cashier
 Revenues Section
 Mail Code 214
 P.O. Box 13088
 Austin, TX 78711-3088

AUSTIN REGIONAL OFFICE

- Overnight Delivery to TNRCC:
 TNRCC - Cashier
 12100 Park 35 Circle
 Building A, 3rd Floor
 Austin, TX 78753
 512/239-0347

Type of Plan	Size	Fee Due
Water Pollution Abatement, One Single Family Residential Dwelling	Acres	\$
Water Pollution Abatement, Multiple Single Family Residential and Parks	Acres	\$
Water Pollution Abatement, Non-residential	28.56 Acre	\$ 5,000
Sewage Collection System	L.F.	\$
Lift Stations without sewer lines	Acres	\$
Underground or Aboveground Storage Tank Facility	Tanks	\$
Piping System(s)(only)	Each	\$
Exception	Each	\$
Extension of Time	Each	\$

Cara C. Zickert
Signature

08/21/02
Date

TEXAS NATURAL RESOURCE CONSERVATION COMMISSION
EDWARDS AQUIFER PROTECTION PLAN
 APPLICATION FEE SCHEDULE
 30 TAC §213.14 (effective 11/14/97) & 30 TAC §213.9 (effective 6/1/99)

WATER POLLUTION ABATEMENT PLANS AND MODIFICATIONS

PROJECT	PROJECT AREA IN ACRES	FEE
One Single Family Residential Dwelling	<5	\$500
Multiple Single Family Residential and Parks	<5	\$1,000
	5 < 10	\$2,000
	10 < 50	\$3,000
	≥50	\$5,000
Non-residential (Commercial, industrial, institutional, multi-family residential, schools, and other sites where regulated activities will occur)	< 1	\$2,000
	1 < 5	\$3,000
	5 < 10	\$4,000
	≥10	\$5,000

ORGANIZED SEWAGE COLLECTION SYSTEMS AND MODIFICATIONS

PROJECT	COST PER LINEAR FOOT	MINIMUM FEE MAXIMUM FEE
Sewage Collection Systems	\$0.50	\$500 - \$5,000

**UNDERGROUND AND ABOVEGROUND STORAGE TANK SYSTEM
 FACILITY PLANS AND MODIFICATIONS**

PROJECT	COST PER TANK OR PIPING SYSTEM	MINIMUM FEE MAXIMUM FEE
Underground and Aboveground Storage Tank Facility	\$500	\$500 - \$5,000

EXCEPTION REQUESTS

PROJECT	FEE
Exception Request	\$250

EXTENSION OF TIME REQUESTS

PROJECT	FEE
Extension of Time Request	\$100

Reorder from: Anton Systems Forms & Supplies Direct 800-992-1970 Form #703A ©Copyright 1994

Invoice No.	Inv. Date	Amount	Discount	Description	Voucher No.	Net Amount
071102TNRC	07/11/02	2,000.00	0.00 7871-0000	AQUIFER PROTECTION PLAN Amount: 2,000.00	00016	2,000.00
TOTAL		<u>2,000.00</u>	<u>0.00</u>			<u>2,000.00</u>

"ORIGINAL CHECK HAS AN ARTIFICIAL WATER MARK ON REVERSE SIDE - HOLD AT AN ANGLE TO VIEW"

NEW BRAUNFELS SERVICE CENTER LTD.

4040 BROADWAY, SUITE 522
SAN ANTONIO, TX 78209
PHONE: (210) 822-5220

NEW BRAUNFELS SERVICE CTR LTD
TEXAS CAPITAL BANK
SAN ANTONIO, TX

32-1797 / 1110

001020

DATE	CHECK NO.	AMOUNT
07/11/02	001020	\$*****2,000.00*

TWO THOUSAND AND NO/100 DOLLARS *****

PAY
TO THE
ORDER OF

TNRCC CASHIER
REVENUES SECTION
MAIL CODE 214
AUSTIN, TX 78711-3088



⑈001020⑈ ⑆111017979⑆ 5011003968⑈

PAPE-DAWSON ENGINEERS, INC.

555 East Ramsey San Antonio, Texas 78216



FROST NATIONAL BANK
SAN ANTONIO, TEXAS

038491

AUGUST 21, 2002

PAY *****3000***** DOLLARS AND *00* CENTS \$ **\$3000.00*

TO THE
ORDER
OF

T.N.R.C.C.

PAPE-DAWSON
CONSULTING ENGINEERS, INC.

AUTHORIZED SIGNATURE

⑈038491⑈ ⑆114923222⑆ 29 3997995⑈

**HERITAGE BUSINESS PARK
WATER POLLUTION ABATEMENT PLAN MODIFICATION**

EXHIBITS

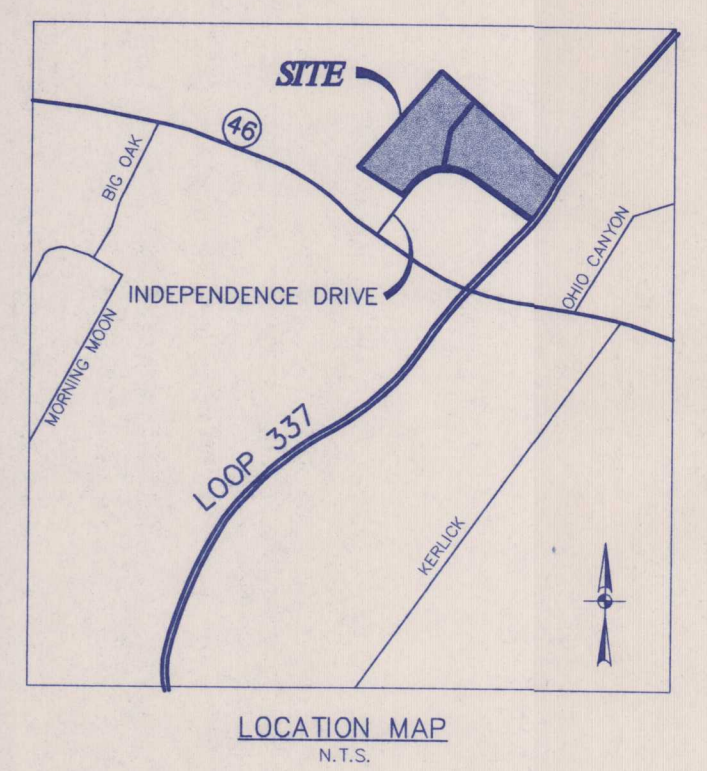
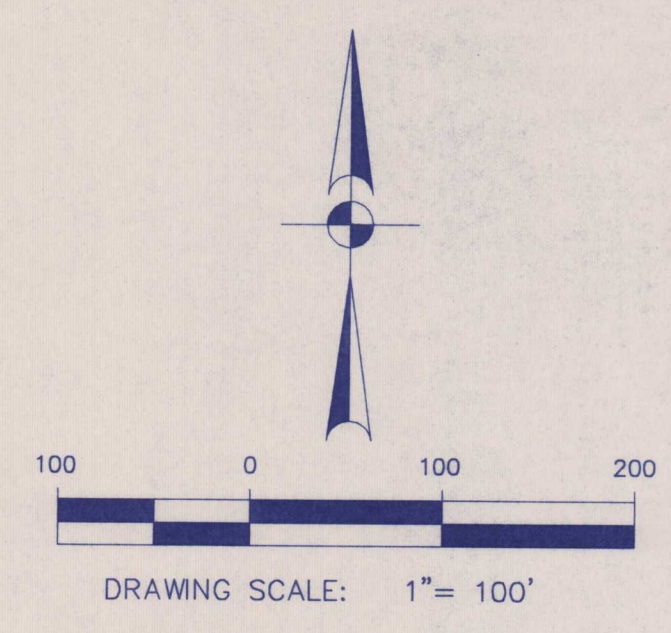
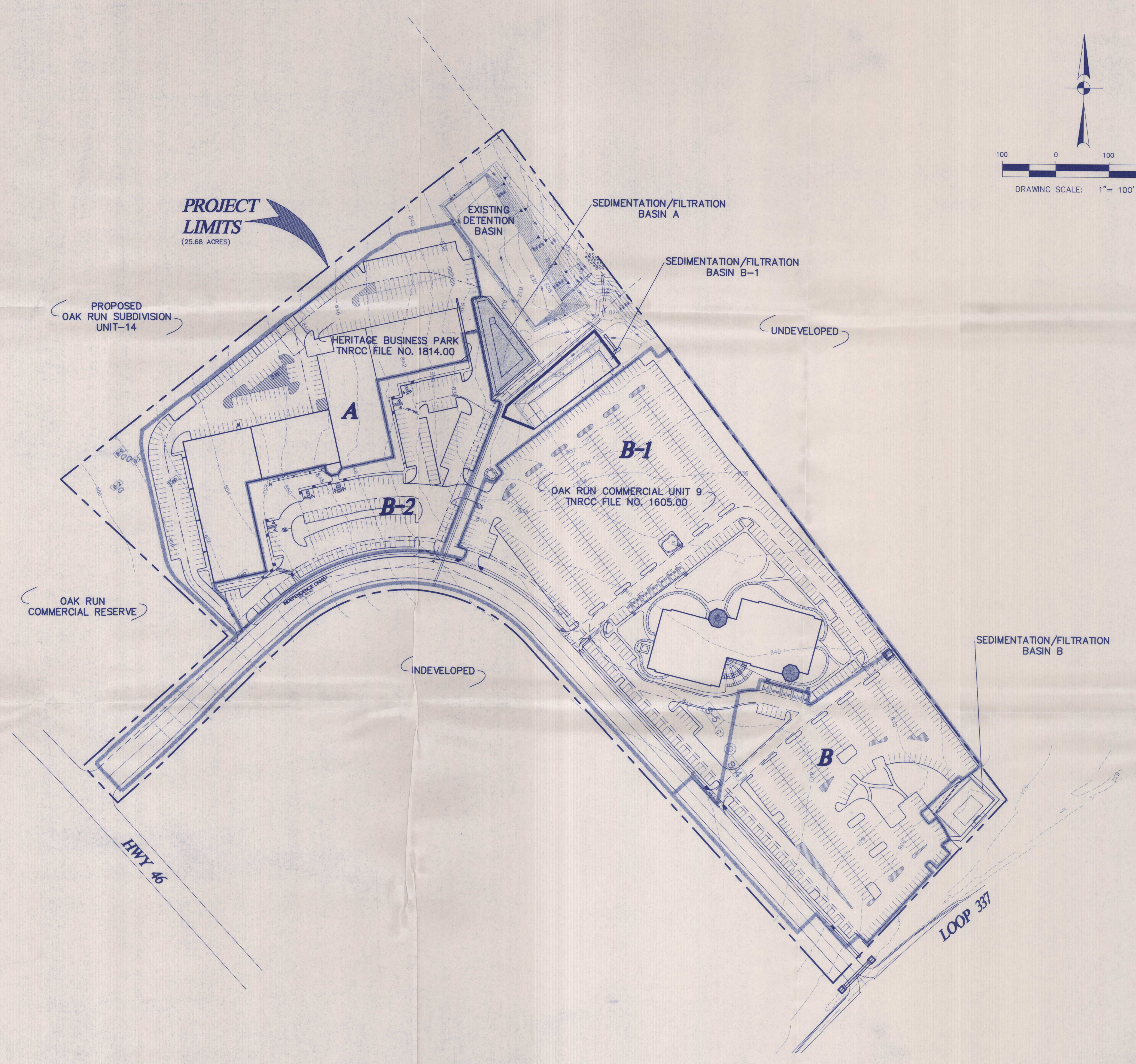

LEGEND	
	PERSON FORMATION
	POTENTIAL RECHARGE FEATURE (ON-SITE)
	EXISTING CONTOURS
	PROJECT LIMITS
	DRAINAGE AREA

REVISIONS:



PAPE-DAWSON ENGINEERS
 555 EAST RAMSEY | SAN ANTONIO TEXAS 78216 | PHONE: 210.375.9000 | FAX: 210.375.9010

**HERITAGE BUSINESS PARK
 OVERALL SITE PLAN**

JOB NO. 5329.02
 DATE AUGUST, 2002
 DESIGNER JD
 CHECKED DR DRAWN RLS
 SHEET 1 OF 1

THE ENGINEERING SEAL HAS BEEN AFFIXED TO THIS SHEET ONLY FOR THE PURPOSE OF DEMONSTRATING COMPLIANCE WITH THE POLLUTION ABATEMENT SIZING AND TREATMENT REQUIREMENTS OF THE TEXAS NATURAL RESOURCE CONSERVATION COMMISSION'S EDWARDS AQUIFER TECHNICAL GUIDANCE MANUAL.
 THIS SHEET HAS BEEN PREPARED FOR PURPOSES OF POLLUTION ABATEMENT ONLY. ALL OTHER CIVIL ENGINEERING RELATED INFORMATION SHOULD BE ACQUIRED FROM THE APPROPRIATE SHEET IN THE CIVIL IMPROVEMENT PLANS.

EXHIBIT 1

TEMPORARY BMP MODIFICATIONS		
DATE	SIGNATURE	DESCRIPTION

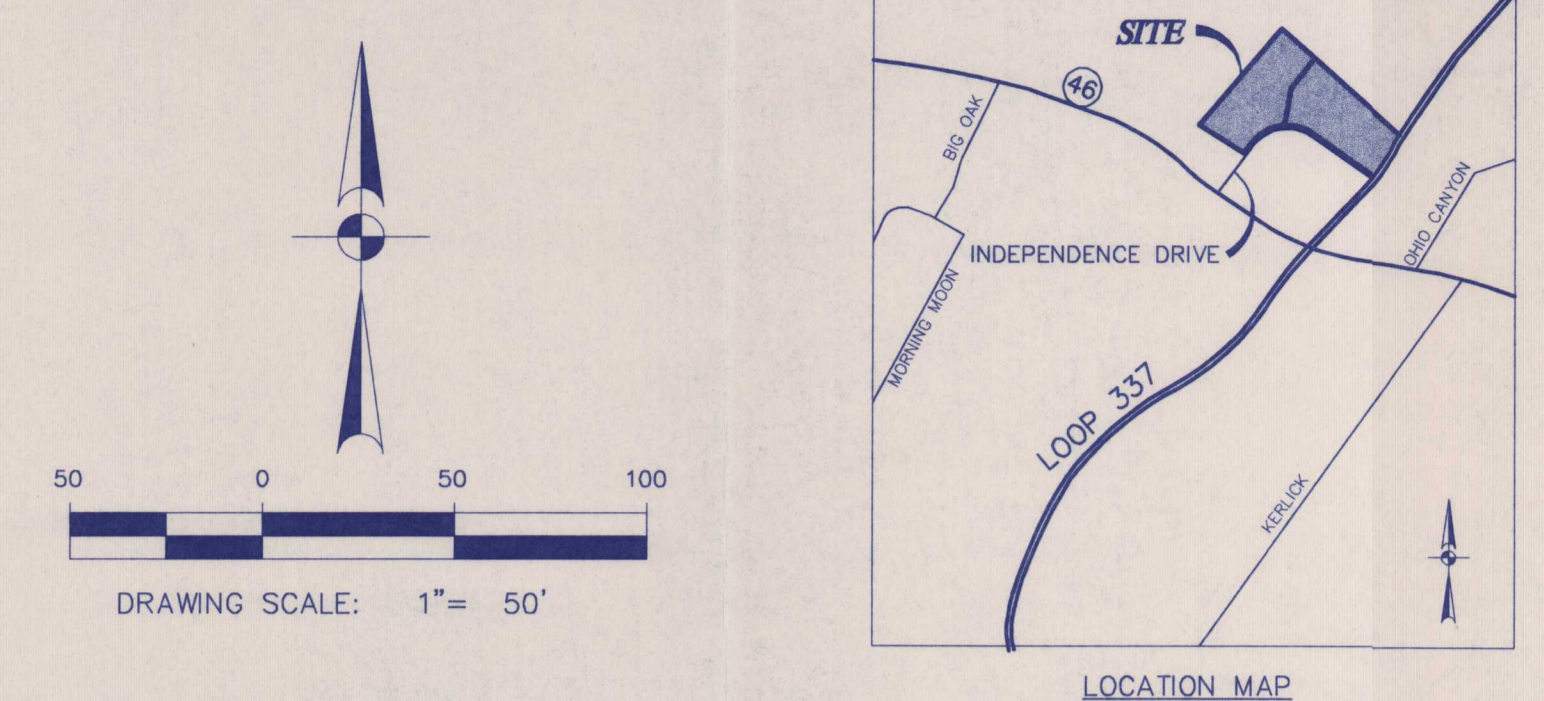

LEGEND	
	PERSON FORMATION
	POTENTIAL RECHARGE FEATURE (ON-SITE)
	STABILIZED CONSTRUCTION ENTRANCE/EXIT
	CONCRETE TRUCK WASHOUT PIT
	CONSTRUCTION STAGING AREA (TO BE FIELD LOCATED)
	SILT FENCING
	ROCK BERM
	CURB INLET GRAVEL FILTER
	DRAINAGE FLOW (EXISTING) SEE EXHIBIT 2 FOR PROPOSED FLOW
	EXISTING CONTOURS
	PROJECT LIMITS
	PHASE LIMITS
	REVISED STORM DRAIN
	ORIGINAL STORM DRAIN

- GENERAL NOTES:
- DO NOT DISTURB VEGETATED AREAS (TREES, GRASS, WEEDS, BRUSH, ETC.) ANY MORE THAN NECESSARY FOR CONSTRUCTION.
 - CONSTRUCTION ENTRANCE/EXIT LOCATION, CONCRETE WASHOUT PIT, AND CONSTRUCTION EQUIPMENT AND MATERIAL STORAGE YARD TO BE DETERMINED IN THE FIELD.
 - STORM WATER POLLUTION PREVENTION CONTROLS MAY NEED TO BE MODIFIED IN THE FIELD TO ACCOMPLISH THE DESIRED EFFECT. ALL MODIFICATIONS ARE TO BE NOTED ON THIS EXHIBIT AND SIGNED AND DATED BY THE RESPONSIBLE PARTY.
 - RESTRICT ENTRY/EXIT TO THE PROJECT SITE TO DESIGNATED LOCATIONS BY USE OF ADEQUATE FENCING, IF NECESSARY.
 - ALL STORM WATER POLLUTION PREVENTION CONTROLS ARE TO BE MAINTAINED AND IN WORKING CONDITION AT ALL TIMES.
 - AS SOON AS PRACTICAL, ALL DISTURBED SOIL THAT WILL NOT BE COVERED BY IMPERVIOUS COVER WILL BE STABILIZED PER APPLICABLE PROJECT SPECIFICATIONS.
 - BEST MANAGEMENT PRACTICES MAY BE INSTALLED IN STAGES TO COINCIDE WITH THE DISTURBANCE OF UPGRADIENT AREAS.
 - BEST MANAGEMENT PRACTICES MAY BE REMOVED IN STAGES ONCE THE WATER SHED FOR THAT PORTION CONTROLLED BY THE BEST MANAGEMENT PRACTICE HAS BEEN STABILIZED.
 - ALL TEMPORARY BMP'S WILL BE REMOVED ONCE WATERSHED IS STABILIZED.
 - MUD OR DIRT INADVERTENTLY TRACKED OFF-SITE AND ONTO EXISTING STREETS SHALL BE REMOVED IMMEDIATELY BY HAND OR MECHANICAL BROOM SWEEPING.
 - STORM DRAIN INLETS SHALL BE PROTECTED BY TEMPORARY MEASURES IN A MANNER TO MINIMIZE THE AMOUNT OF SEDIMENT BUILD UP WITHIN THE STORM DRAIN SYSTEM AND SEDIMENTATION BASIN.
 - SEDIMENT ACCUMULATION IN WATER QUALITY BASIN SHALL BE REMOVED AND PROPERLY DISPOSED OF BY CONTRACTOR(S) FOLLOWING CONSTRUCTION.
 - SEDIMENTATION/FILTRATION BASIN AND ASSOCIATED STORM DRAIN PIPES ARE TO BE COMPLETED WITH PHASE 1 CONSTRUCTION.

- TEXAS NATURAL RESOURCE CONSERVATION COMMISSION
WATER POLLUTION ABATEMENT PLAN
GENERAL CONSTRUCTION NOTES
- WRITTEN CONSTRUCTION NOTIFICATION MUST BE GIVEN TO THE APPROPRIATE TNRC REGIONAL OFFICE NO LATER THAN 48 HOURS PRIOR TO COMMENCEMENT OF THE REGULATED ACTIVITY. INFORMATION MUST INCLUDE: THE DATE ON WHICH THE REGULATED ACTIVITY WILL COMMENCE, THE NAME OF THE APPROVED PLAN FOR THE REGULATED ACTIVITY, AND THE NAME OF THE PRIME CONTRACTOR AND THE NAME AND TELEPHONE NUMBER OF THE CONTACT PERSON.
 - ALL CONTRACTORS CONDUCTING REGULATED ACTIVITIES ASSOCIATED WITH THIS PROJECT MUST BE PROVIDED WITH COMPLETE COPIES OF THE APPROVED WATER POLLUTION ABATEMENT PLAN AND THE TNRC LETTER INDICATING THE SPECIFIC CONDITIONS OF ITS APPROVAL. DURING THE COURSE OF THESE REGULATED ACTIVITIES, THE CONTRACTORS ARE REQUIRED TO KEEP COMPLETE COPIES OF THE APPROVED PLAN AND APPROVAL LETTER.
 - IF ANY SENSITIVE FEATURE IS DISCOVERED DURING CONSTRUCTION, ALL REGULATED ACTIVITIES NEAR THE SENSITIVE FEATURE MUST BE SUSPENDED IMMEDIATELY. THE APPROPRIATE TNRC REGIONAL OFFICE MUST BE IMMEDIATELY NOTIFIED OF ANY SENSITIVE FEATURES ENCOUNTERED DURING CONSTRUCTION. THE REGULATED ACTIVITIES NEAR THE SENSITIVE FEATURE MAY NOT PROCEED UNTIL THE TNRC HAS REVIEWED AND APPROVED THE METHODS PROPOSED TO PROTECT THE SENSITIVE FEATURE AND THE EDWARDS AQUIFER FROM ANY POTENTIALLY ADVERSE IMPACTS TO WATER QUALITY.
 - NO TEMPORARY ABOVEGROUND HYDROCARBON AND HAZARDOUS SUBSTANCE STORAGE TANK SYSTEM IS INSTALLED WITHIN 150 FEET OF A DOMESTIC, INDUSTRIAL, IRRIGATION, OR PUBLIC WATER SUPPLY WELL, OR OTHER SENSITIVE FEATURE.
 - ALL TEMPORARY EROSION AND SEDIMENTATION (E&S) CONTROL MEASURES MUST BE PROPERLY SELECTED, INSTALLED, AND MAINTAINED IN ACCORDANCE WITH THE MANUFACTURER'S SPECIFICATIONS AND GOOD ENGINEERING PRACTICES. CONTROLS SPECIFIED IN THE TEMPORARY STORM WATER SECTION OF THE APPROVED EDWARDS AQUIFER PROTECTION PLAN ARE REQUIRED DURING CONSTRUCTION. IF INSPECTIONS INDICATE A CONTROL HAS BEEN USED INAPPROPRIATELY, OR INCORRECTLY, THE APPLICANT MUST REPLACE OR MODIFY THE CONTROL, FOR SITE SITUATIONS, THE CONTROLS MUST REMAIN IN PLACE UNTIL DISTURBED AREAS ARE REVEGETATED AND THE AREAS HAVE BECOME PERMANENTLY STABILIZED.
 - IF SEDIMENT ESCAPES THE CONSTRUCTION SITE, OFF-SITE ACCUMULATIONS OF SEDIMENT MUST BE REMOVED AT A FREQUENCY SUFFICIENT TO MINIMIZE OFFSITE IMPACTS TO WATER QUALITY (E.G., FUGITIVE SEDIMENT IN STREET BEING WASHED INTO SURFACE STREAMS OR SENSITIVE FEATURES BY THE NEXT RAIN).
 - SEDIMENT MUST BE REMOVED FROM SEDIMENT TRAPS OR SEDIMENTATION PONDS NOT LATER THAN WHEN DESIGN CAPACITY HAS BEEN REDUCED BY 50%. A PERMANENT STAKE MUST BE PROVIDED THAT CAN INDICATE WHEN THE SEDIMENT OCCURS 50% OF THE BASIN VOLUME.
 - LITTER, CONSTRUCTION DEBRIS, AND CONSTRUCTION CHEMICALS EXPOSED TO STORMWATER SHALL BE PREVENTED FROM BECOMING A POLLUTANT SOURCE FOR STORMWATER DISCHARGES (E.G., SCREENING OUTFALLS, PICKED UP DIRT).
 - ALL SPOILS (EXCAVATED MATERIAL) GENERATED FROM THE PROJECT SITE MUST BE STORED ON-SITE WITH PROPER E&S CONTROLS. FOR STORAGE OR DISPOSAL OF SPOILS AT ANOTHER SITE, ON THE EDWARDS AQUIFER RECHARGE ZONE, THE OWNER OF THE SITE MUST RECEIVE APPROVAL OF A WATER POLLUTION ABATEMENT PLAN FOR THE PLACEMENT OF FILL MATERIAL OR MASS GRADING PRIOR TO THE PLACEMENT OF SPOILS AT THE OTHER SITE.
 - STABILIZATION MEASURES SHALL BE INITIATED AS SOON AS PRACTICABLE IN PORTIONS OF THE SITE WHERE CONSTRUCTION ACTIVITIES HAVE TEMPORARILY OR PERMANENTLY CEASED, BUT IN NO CASE MORE THAN 14 DAYS AFTER THE CONSTRUCTION ACTIVITY IN THAT PORTION OF THE SITE HAS TEMPORARILY OR PERMANENTLY CEASED. WHERE THE INITIATION OF STABILIZATION MEASURES BY THE 14TH DAY AFTER CONSTRUCTION ACTIVITY TEMPORARILY OR PERMANENTLY CEASES IS PRECEDDED BY WEATHER CONDITIONS, STABILIZATION MEASURES SHALL BE INITIATED AS SOON AS PRACTICABLE WHERE CONSTRUCTION ACTIVITY ON A PORTION OF THE SITE IS TEMPORARILY CEASED, AND EARTH DISTURBING ACTIVITIES WILL BE RESUMED WITHIN 21 DAYS; TEMPORARY STABILIZATION MEASURES DO NOT HAVE TO BE INITIATED ON THAT PORTION OF THE SITE IN AREAS WHERE THE INITIATION OF STABILIZATION MEASURES BY THE 14TH DAY AFTER CONSTRUCTION ACTIVITY HAS TEMPORARILY OR PERMANENTLY CEASED IS PRECEDDED BY SEASONAL AND CONDITIONS; STABILIZATION MEASURES SHALL BE INITIATED AS SOON AS PRACTICABLE.
 - THE FOLLOWING RECORDS SHALL BE MAINTAINED AND MADE AVAILABLE TO THE TNRC UPON REQUEST: THE DATES WHEN MAJOR GRADING ACTIVITIES OCCUR, THE DATES WHEN CONSTRUCTION ACTIVITIES TEMPORARILY OR PERMANENTLY CEASE ON A PORTION OF THE SITE, AND THE DATES WHEN STABILIZATION MEASURES ARE INITIATED.
 - THE HOLDER OF ANY APPROVED EDWARDS AQUIFER PROTECTION PLAN MUST NOTIFY THE APPROPRIATE REGIONAL OFFICE IN WRITING AND OBTAIN APPROVAL FROM THE EXECUTIVE DIRECTOR PRIOR TO INITIATING ANY OF THE FOLLOWING:
 - ANY PHYSICAL OR OPERATIONAL MODIFICATION OF ANY WATER POLLUTION ABATEMENT STRUCTURE(S), INCLUDING BUT NOT LIMITED TO PONDS, DAMS, BERMS, SEWAGE TREATMENT PLANTS, AND OVERFLOW STRUCTURES;
 - ANY CHANGE IN THE NATURE OR CHARACTER OF THE REGULATED ACTIVITY FROM THAT WHICH WAS ORIGINALLY APPROVED OR A CHANGE WHICH WOULD SIGNIFICANTLY IMPACT THE ABILITY OF THE PLAN TO PREVENT POLLUTION OF THE EDWARDS AQUIFER;
 - ANY DEVELOPMENT OF LAND PREVIOUSLY IDENTIFIED AS UNDEVELOPED IN THE ORIGINAL WATER POLLUTION ABATEMENT PLAN.

SAN ANTONIO REGIONAL OFFICE
14250 JUDSON RD.
SAN ANTONIO, TEXAS 78253-4480
PHONE: (210) 490-3096
FAX: (210) 545-4329

THE ENGINEERING SEAL HAS BEEN AFFIXED TO THIS SHEET ONLY FOR THE PURPOSE OF DEMONSTRATING COMPLIANCE WITH THE POLLUTION ABATEMENT SIZING AND TREATMENT REQUIREMENTS OF THE TEXAS NATURAL RESOURCE CONSERVATION COMMISSION'S EDWARDS AQUIFER TECHNICAL GUIDANCE MANUAL.

THIS SHEET HAS BEEN PREPARED FOR PURPOSES OF POLLUTION ABATEMENT ONLY. ALL OTHER CIVIL ENGINEERING RELATED INFORMATION SHOULD BE ACQUIRED FROM THE APPROPRIATE SHEET IN THE CIVIL IMPROVEMENT PLANS.

EXHIBIT 2

JOB NO.	5329.02
DATE	AUGUST 2002
DESIGNER	DJM
CHECKED	GS
DRAWN	JJJ
SHEET	C-6

HERITAGE BUSINESS PARK
 WPAP MODIFICATION
 TEMPORARY POLLUTION ABATEMENT PLAN

PAPE-DAWSON ENGINEERS
 555 EAST RAMSEY | SAN ANTONIO, TEXAS 78216 | PHONE: 210.375.9000
 FAX: 210.375.9010

REVISIONS:

File: P:\53129\02\DESIGN\CIVIL\WMS2301A1.dwg

REVISIONS:



PAPE-DAWSON ENGINEERS
 555 EAST RAMSEY | SAN ANTONIO TEXAS 78216 | PHONE: 210.375.9000 | FAX: 210.375.9010

**HERITAGE BUSINESS PARK
 WPAP MODIFICATION
 PERMANENT POLLUTION ABATEMENT PLAN**

JOB NO. 5329.02
 DATE AUGUST 2002
 DESIGNER DJM
 CHECKED GS DRAWN JJJ
 SHEET C-7

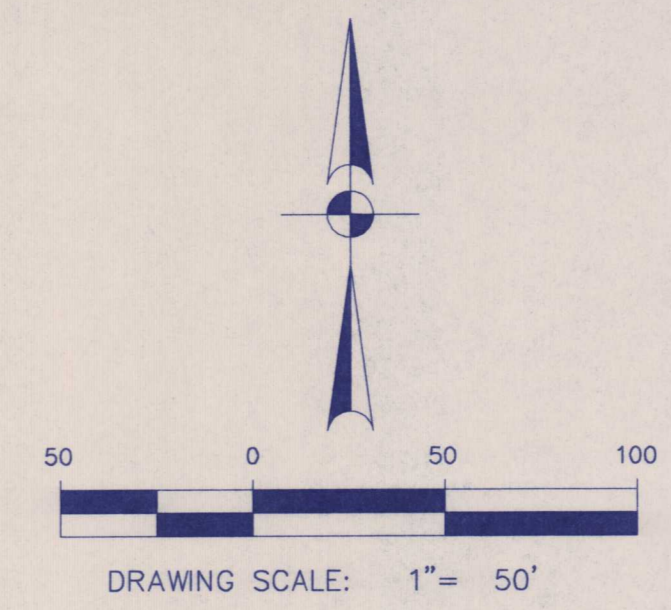
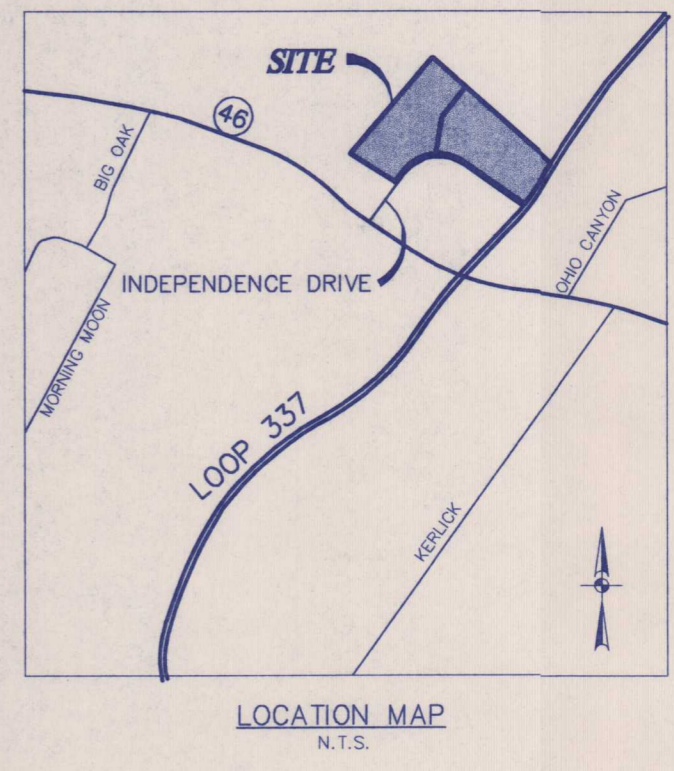

LEGEND

	PERSON FORMATION
	POTENTIAL RECHARGE FEATURE (ON-SITE)
	DRAINAGE FLOW (PROPOSED)
	EXISTING CONTOURS
	PROJECT LIMITS
	DRAINAGE AREA
	REVISED STORM DRAIN
	ORIGINAL STORM DRAIN

- SUMMARY OF PERMANENT POLLUTION ABATEMENT MEASURES:**
- SILT FENCE WILL BE MAINTAINED UNTIL THE PARKING, ROADWAY, UTILITIES, AND DRAINAGE IMPROVEMENTS FOR EACH PHASE IS COMPLETED.
 - SEDIMENTATION/FILTRATION BASIN "A" WILL BE CONVERTED FROM A TEMPORARY SEDIMENT TRAP TO A PERMANENT BASIN AND FILTER MEDIA INSTALLED AFTER 70% OF THE IMPROVEMENTS ARE COMPLETE.
 - BASIN B-1 IS TO REMAIN OPERATIONAL DURING CONSTRUCTION ACTIVITIES TO INCREASE THE VOLUME OF THE BASIN. NO STORMWATER RUNOFF, INTENDED TO BE CAPTURED, WILL BE DIVERTED.
 - AFTER COMPLETION OF CONSTRUCTION, THE CONTRACTOR WILL REMOVE TRASH, DEBRIS, AND ACCUMULATED SILT FROM THE SEDIMENTATION/FILTRATION BASIN AND RE-ESTABLISH IT TO PROPER OPERATING CONDITION.
 - STORMWATER RUNOFF FROM WITHIN THE COMMERCIAL DEVELOPMENT WILL BE DISCHARGED TO TWO SEDIMENTATION/FILTRATION BASINS. EACH BASIN HAS BEEN DESIGNED TO REMOVE 80% OF THE INCREASED TOTAL SUSPENDED SOLIDS (TSS) FOR ITS WATERSHED IN ACCORDANCE WITH THE TNRCC'S TECHNICAL GUIDANCE MANUAL RG-348 (1999).
 - SEDIMENTATION/FILTRATION BASIN "A" HAS BEEN DESIGNED TO TREAT THE AREA LABELED "FUTURE PARKING EXPANSION AREA" SHOWN ON THIS PLAN.

WATERSHEDS

DRAINAGE AREA	AREA (AC.)	IMPERVIOUS COVER(AC.)	% IMPERVIOUS COVER	ESTIMATED Q25 (CFS)
A	5.03*	4.53	90.0	43.3
B1 + B2	12.8*	10.89	85.0	88.8

*INCLUDES BASIN FOOTPRINT

SEDIMENTATION/FILTRATION BASIN

BASIN	DRAINAGE AREA	DRAINAGE AREA (AC.)	REQUIRED SAND AREA (SF)	REQUIRED CAPTURE VOL. (CF)	RUNOFF DEPTH (IN.)	DESIGN SAND AREA (SF)	DESIGN CAPTURE VOL. (CF)
A	A	5.03*	2,437	25,995	1.19	2,720	27,480
B-1	B1 + B2	12.33*	5,981	55,823	1.04	7,264	62,398

*INCLUDES BASIN FOOTPRINT



THE ENGINEERING SEAL HAS BEEN AFFIXED TO THIS SHEET ONLY FOR THE PURPOSE OF DEMONSTRATING COMPLIANCE WITH THE POLLUTION ABATEMENT SIZING AND TREATMENT REQUIREMENTS OF THE TEXAS NATURAL RESOURCE CONSERVATION COMMISSION'S EDWARDS AQUIFER TECHNICAL GUIDANCE MANUAL.

THIS SHEET HAS BEEN PREPARED FOR PURPOSES OF POLLUTION ABATEMENT ONLY. ALL OTHER CIVIL ENGINEERING RELATED INFORMATION SHOULD BE ACQUIRED FROM THE APPROPRIATE SHEET IN THE CIVIL IMPROVEMENT PLANS.

EXHIBIT 3

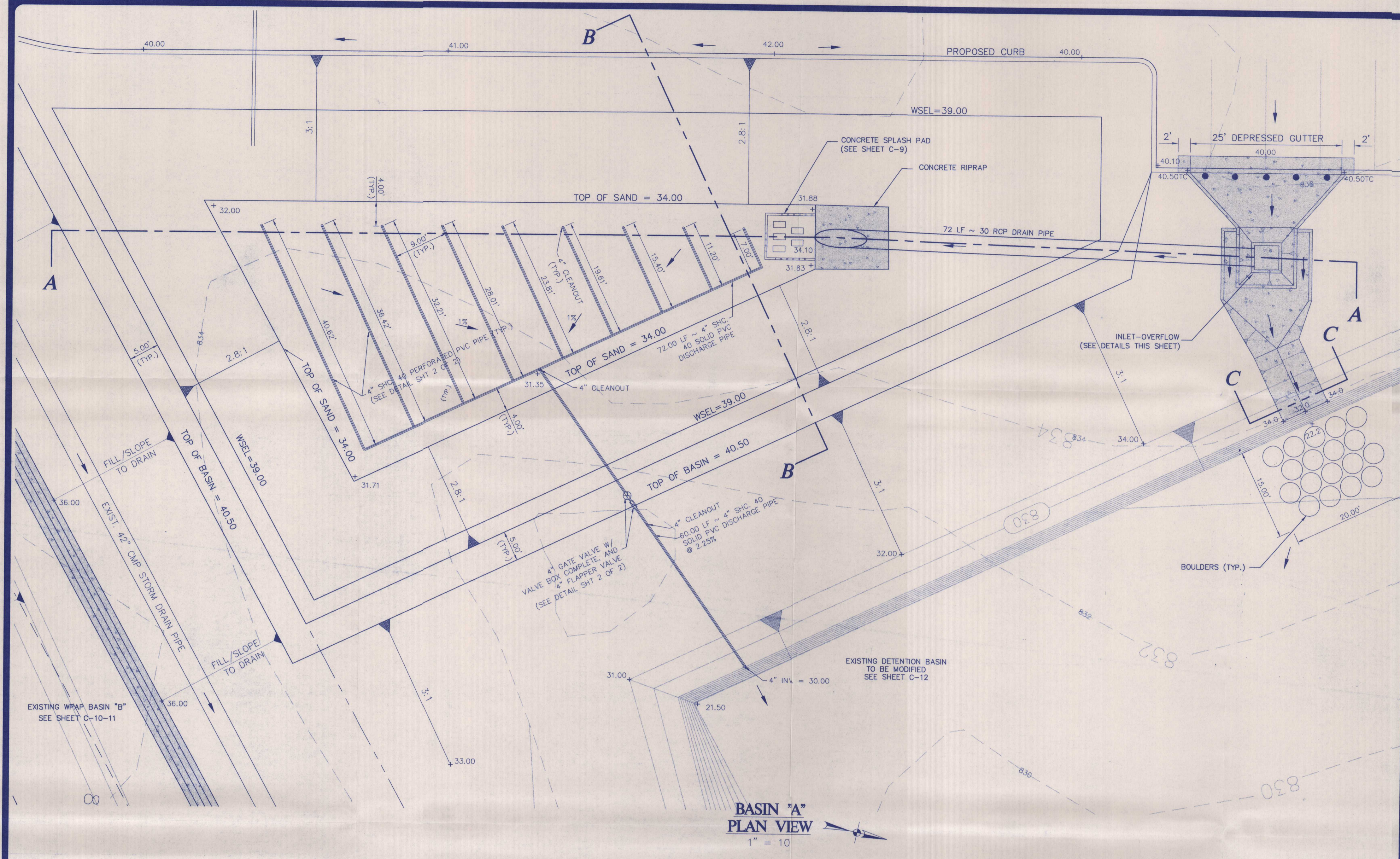

BASIN 'A'
PLAN VIEW
1" = 10'

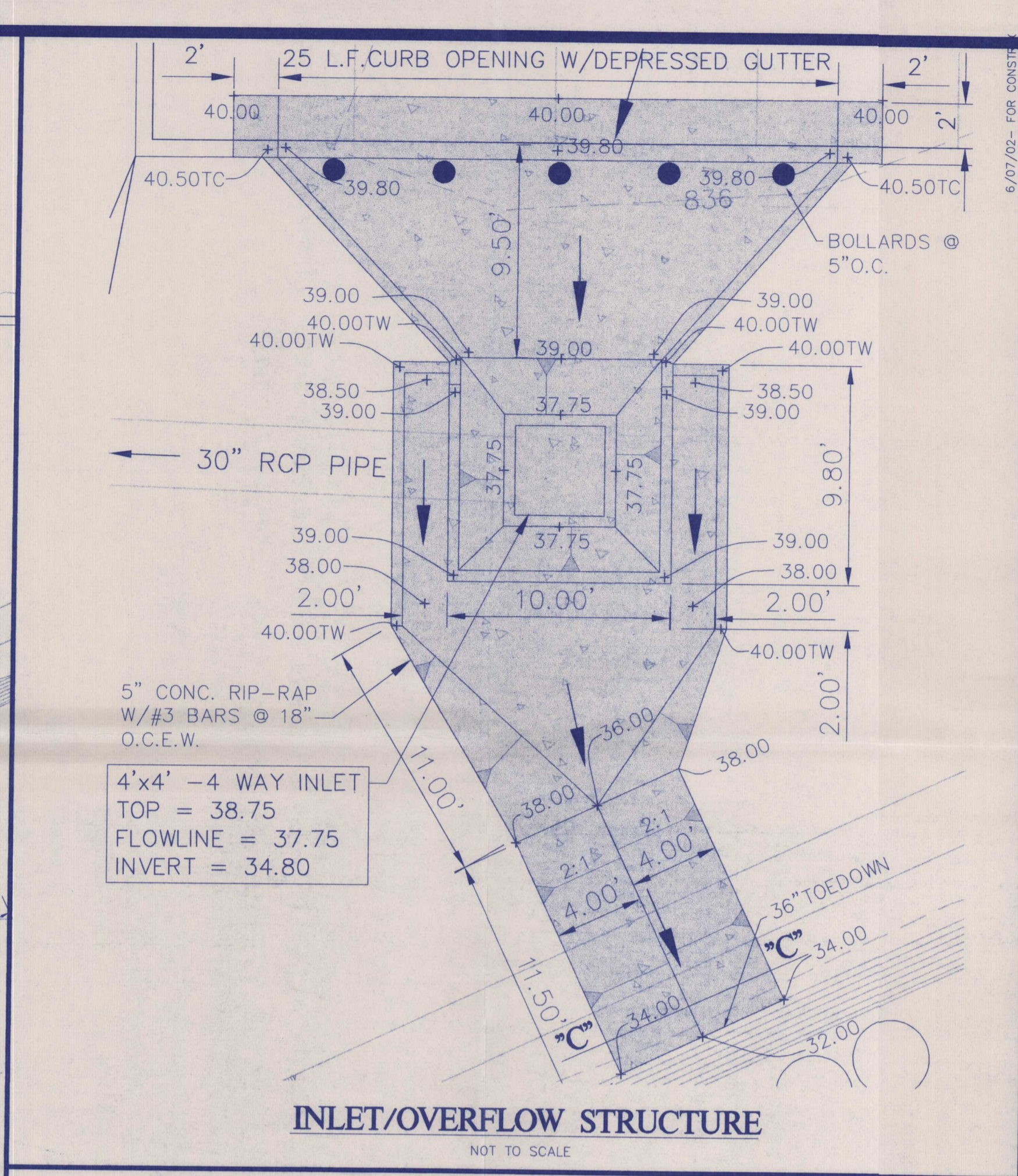

INLET/OVERFLOW STRUCTURE
NOT TO SCALE

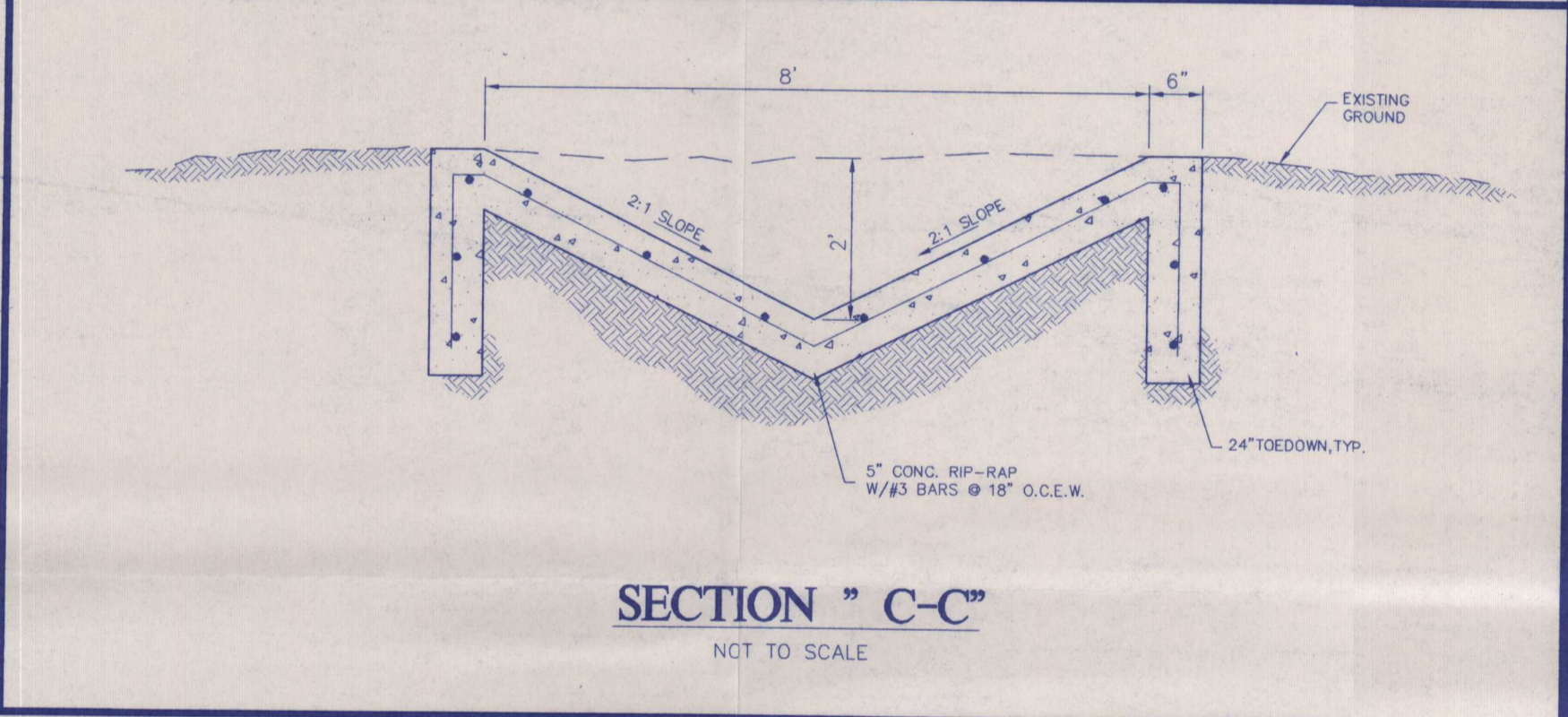

SECTION 'C-C'
NOT TO SCALE

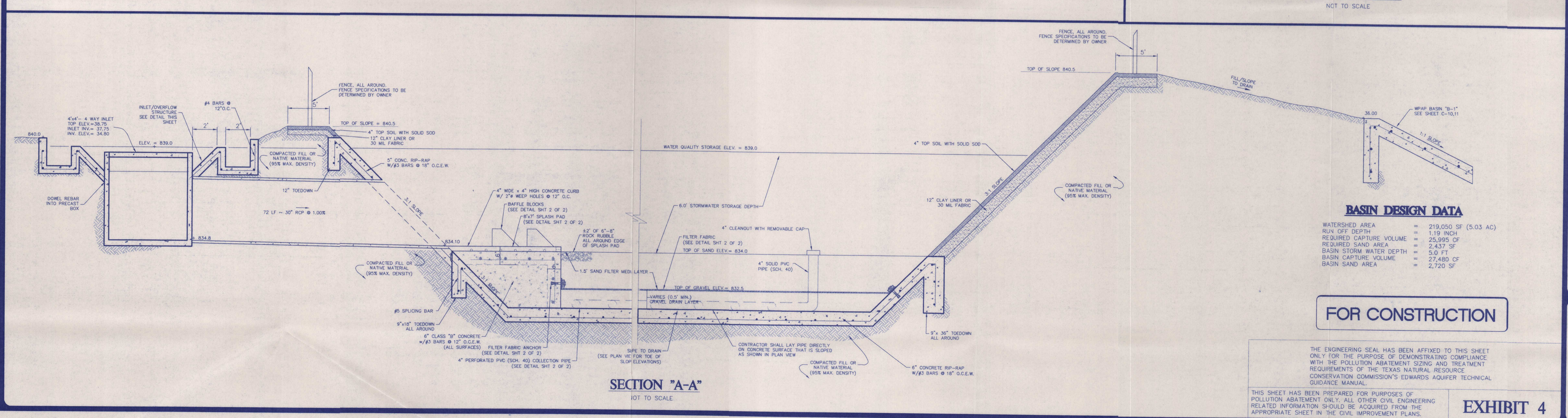

SECTION 'A-A'
NOT TO SCALE

BASIN DESIGN DATA

WATERSHED AREA	= 219,050 SF (5.03 AC)
RUN OFF DEPTH	= 1.19 INCH
REQUIRED CAPTURE VOLUME	= 25,995 CF
REQUIRED SAND AREA	= 2,437 SF
BASIN STORM WATER DEPTH	= 5.0 FT
BASIN CAPTURE VOLUME	= 27,480 CF
BASIN SAND AREA	= 2,720 SF

FOR CONSTRUCTION

THE ENGINEERING SEAL HAS BEEN AFFIXED TO THIS SHEET ONLY FOR THE PURPOSE OF DEMONSTRATING COMPLIANCE WITH THE POLLUTION ABATEMENT SIZING AND TREATMENT REQUIREMENTS OF THE TEXAS NATURAL RESOURCE CONSERVATION COMMISSION'S EDWARDS AQUIFER TECHNICAL GUIDANCE MANUAL.

THIS SHEET HAS BEEN PREPARED FOR PURPOSES OF POLLUTION ABATEMENT ONLY. ALL OTHER CIVIL ENGINEERING RELATED INFORMATION SHOULD BE ACQUIRED FROM THE APPROPRIATE SHEET IN THE CIVIL IMPROVEMENT PLANS.

6/07/02 - FOR CONSTRUCTION

REVISIONS:

8/21/02

PAPE-DAWSON ENGINEERS

555 EAST RAMSEY | SAN ANTONIO TEXAS 78216 | PHONE: 210.375.9000 | FAX: 210.375.9010

HERITAGE BUSINESS PARK
WATER POLLUTION ABATEMENT BASIN 'A'
SHEET 1 OF 2

JOB NO. 5329.02
DATE AUGUST 2002
DESIGNER D.J.M.
CHECKED GS DRAWN J.J.J.
SHEET C-8

EXHIBIT 4

6/07/02 - F
REVISIONS:

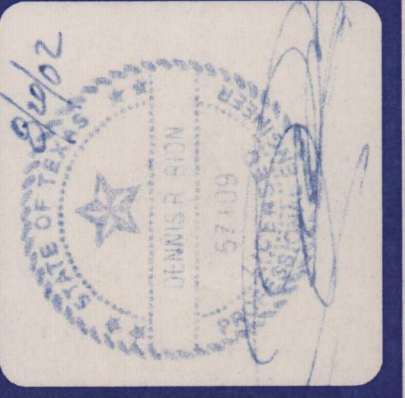

PAPE-DAWSON ENGINEERS
555 EAST RAMSEY | SAN ANTONIO, TEXAS 78216 | PHONE: 210.375.9000
FAX: 210.375.9010

**HERITAGE BUSINESS PARK
WATER POLLUTION ABATEMENT BASIN "A"
SHEET 2 OF 2**

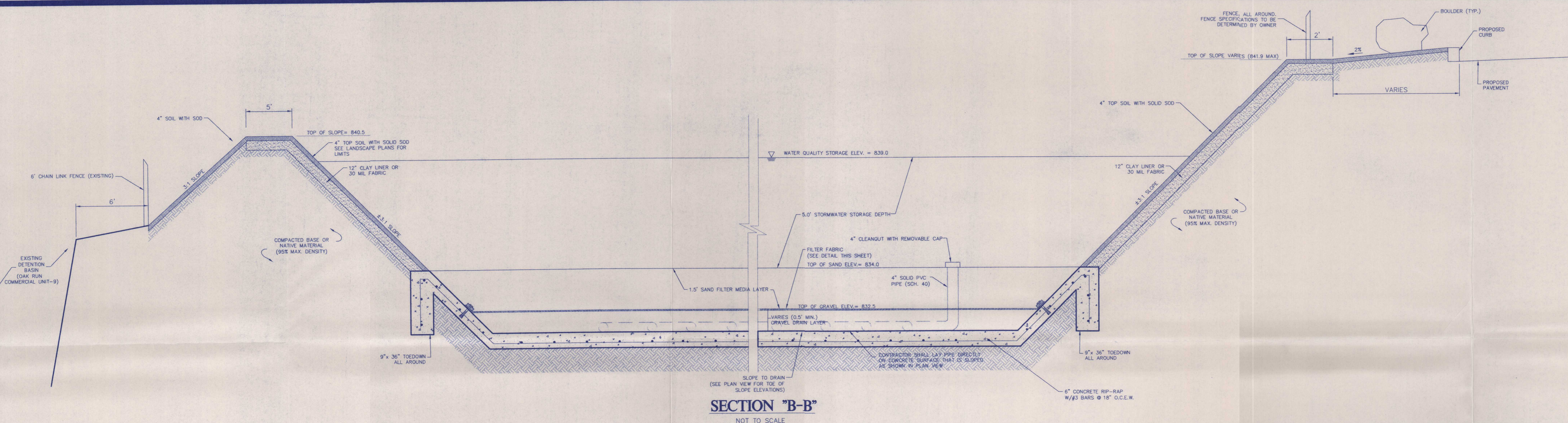

NOTES TO CONTRACTOR

- CONTRACTOR IS ADVISED THAT TNCC DOES NOT ALLOW CHANGES TO PERMANENT POLLUTION ABATEMENT MEASURES WITHOUT THEIR PRIOR APPROVAL.
- CONTRACTOR SHALL NOTIFY CERTIFYING ENGINEER WHEN BASIN CONSTRUCTION HAS PROGRESSED TO THE FOLLOWING MILESTONES:
 - BASIN LINER IN PLACE AND UNDER DRAIN SYSTEM IS IN PLACE WITHOUT GRAVEL.
 - GRAVEL AROUND UNDER DRAIN SYSTEM IS IN PLACE AND FILTER FABRIC IS INSTALLED AND ATTACHED TO WALLS OR RIP-RAP.
 - SAND FILTER MEDIA HAS BEEN PLACED & BASIN HAS BEEN COMPLETELY FINISHED INCLUDING SOD OR SEED PLACEMENT ON SIDE SLOPES (WHERE APPLICABLE).
- WORK SHALL NOT CONTINUE ON THE BASIN UNTIL THE ENGINEER HAS HAD AN OPPORTUNITY TO OBSERVE THE STATUS OF CONSTRUCTION AT EACH STAGE. CONTRACTOR SHALL PROVIDE ENGINEER A MINIMUM OF 24 HOURS ADVANCE NOTICE PRIOR TO TIME THE BASIN WILL BE AT THE REQUIRED STAGE.
- BEFORE FINAL ACCEPTANCE OF CONSTRUCTION BY THE OWNER, THE CONTRACTOR WILL REMOVE ALL TRASH, DEBRIS, AND ACCUMULATED SILT FROM THE BASIN AND RE-ESTABLISH THEM TO THE PROPER OPERATING CONDITION.
- THE MINIMUM DRAIN TIME FOR A FULL BASIN IS 24 HOURS. THE CONTRACTOR SHALL RESTRICT THE FLOW THROUGH ADJUSTING OF THE GATE VALVE ON THE DISCHARGE PIPE, SO AS TO PROVIDE THE MINIMUM 24 HOUR DRAW DOWN TIME.

FILTER FABRIC SPECIFICATIONS

THE SEPARATION LAYER BETWEEN THE FILTER, SAND, AND GRAVEL LAYERS SHALL BE A DRAINAGE MATTING CONSISTING OF NON-WOVEN FILTER FABRIC MEETING THE FOLLOWING SPECIFICATIONS:

PROPERTY	TEST METHOD	SPECIFICATION
WEIGHT (OZ/SY)	ASTM D 3776	40
GRAB STRENGTH (LBS.)	ASTM D 4632	90
ELONGATIONS (%)	ASTM D 4632	55
PUNCTURE (LBS)	ASTM D 3787	60
AOS (SIEVE #)	ASTM D 4751	70-80
FLOW RATE (GPM/SF)	ASTM D 4491	120

FABRIC OVERLAP SHALL BE A MINIMUM OF 24".
ALL OVERLAPS SHALL BE WIRE TIED AT A MAXIMUM OF 36" INTERVALS

NOTE:
SAND FILTER MATERIAL SHALL BE 0.0165" (#40 SIEVE) TO 0.0469" (#16 SIEVE) SILICA BASED WASHED SAND.
ROCK FOR GRAVEL LAYER SHALL BE 1/2" TO 1" DIAMETER WASHED RIVER GRAVEL.

FOR CONSTRUCTION

THE ENGINEERING SEAL HAS BEEN AFFIXED TO THIS SHEET ONLY FOR THE PURPOSE OF DEMONSTRATING COMPLIANCE WITH THE POLLUTION ABATEMENT SIZING AND TREATMENT REQUIREMENTS OF THE TEXAS NATURAL RESOURCE CONSERVATION COMMISSION'S EDWARDS AQUIFER TECHNICAL GUIDANCE MANUAL.

THIS SHEET HAS BEEN PREPARED FOR PURPOSES OF POLLUTION ABATEMENT ONLY. ALL OTHER CIVIL ENGINEERING RELATED INFORMATION SHOULD BE ACQUIRED FROM THE APPROPRIATE SHEET IN THE CIVIL IMPROVEMENT PLANS.

EXHIBIT 4

JOB NO. 5329.02
DATE AUGUST 2002
DESIGNER DJM
CHECKED GS DRAWN JJJ
SHEET C-9

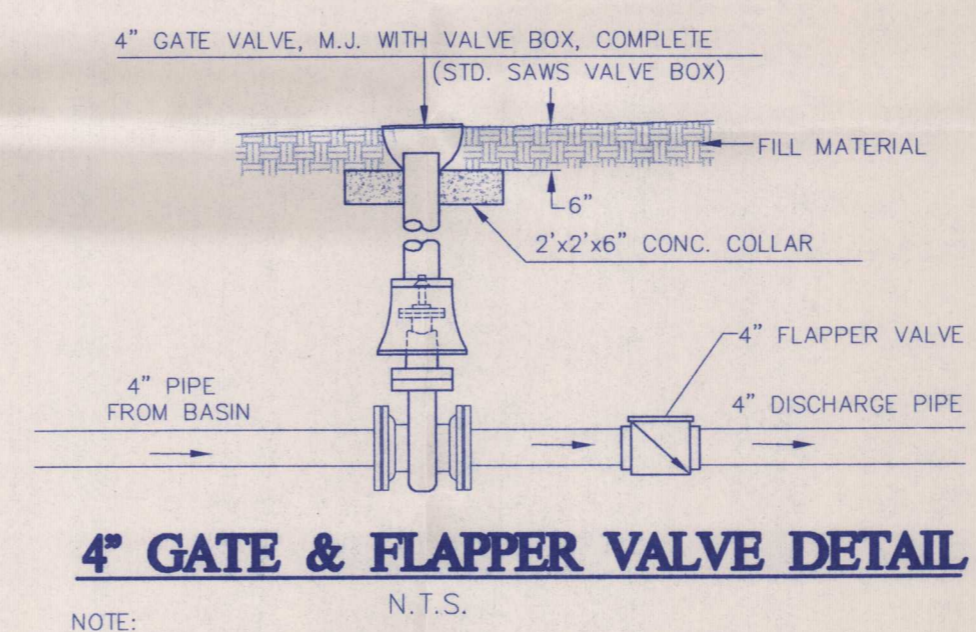
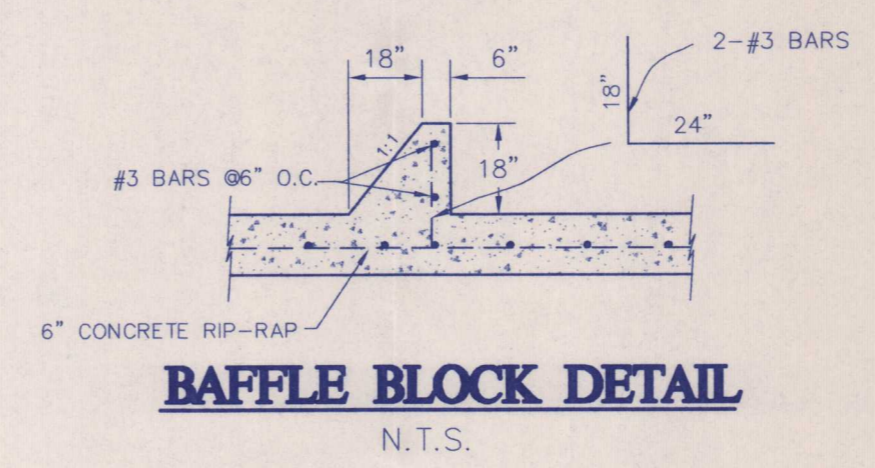
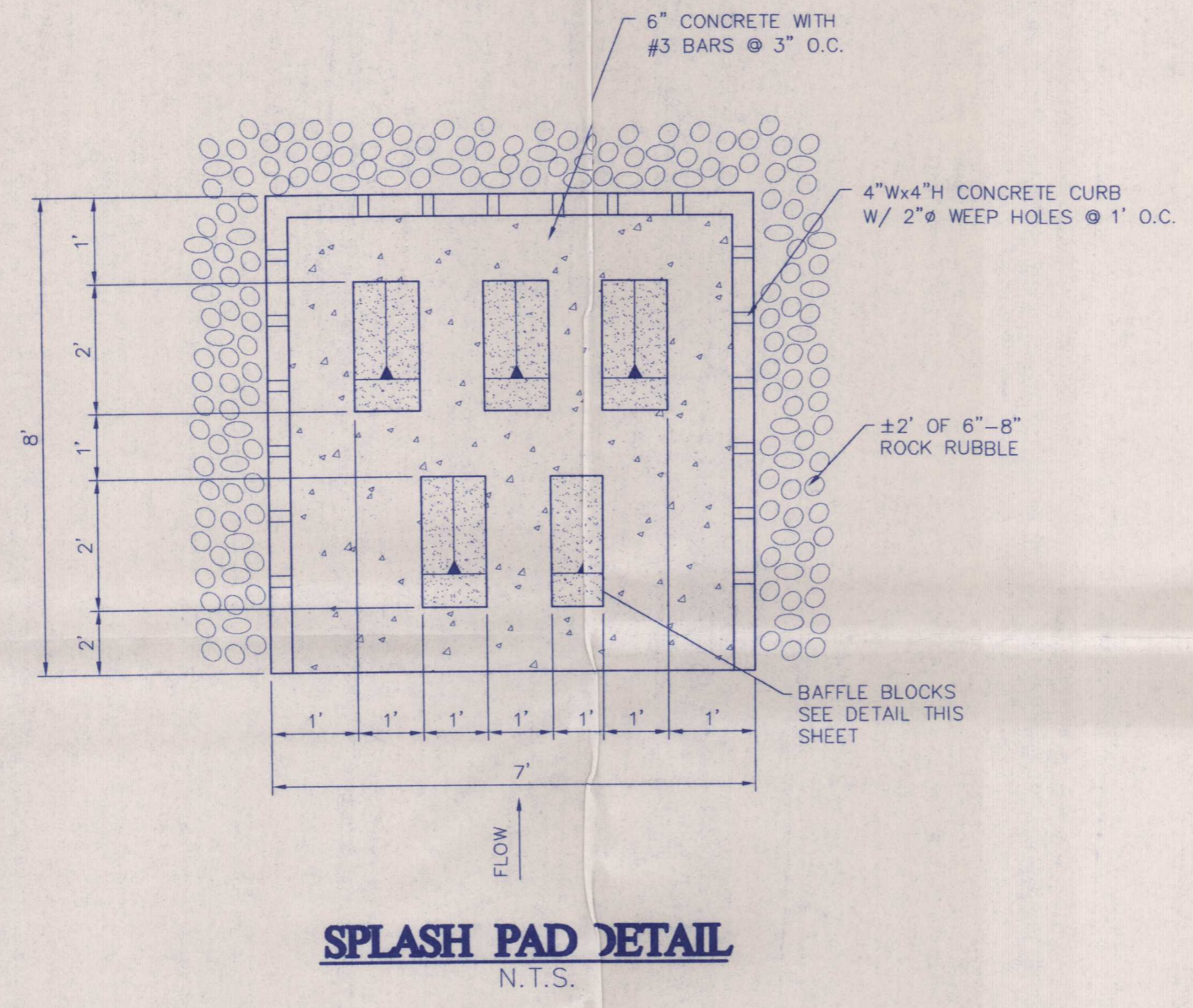

- NOTE:
- VALVE WILL BE SET PARTIALLY CLOSED SO AS TO PROVIDE A MINIMUM DRAWDOWN TIME OF 24 HOURS.
 - CONTRACTOR SHALL PROVIDE OWNER WITH VALVE OPERATING KEY/ROD PRIOR TO PROJECT COMPLETION.

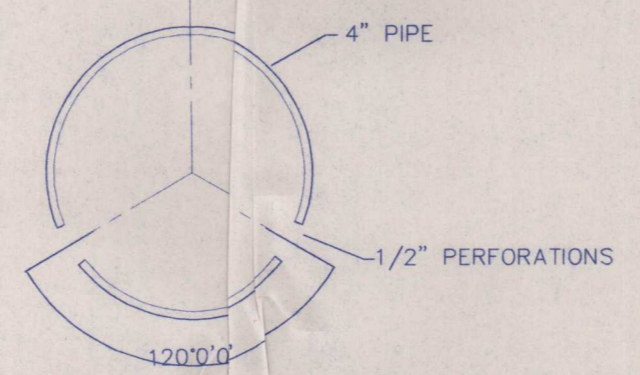

- NOTE:
- MINIMUM DIAMETER = 4", SCHEDULE 40 PVC. (SEE PLAN VIEW)
 - THE MAXIMUM SPACING BETWEEN ROWS OF PERFORATIONS SHOULD NOT EXCEED 6".
 - SET PERFORATIONS DOWN.
 - PERFORATIONS SHOULD BE LESS THAN A 1/2".
 - PIPES SHOULD LIE FLAT ON CONCRETE BOTTOM WHICH HAS BEEN GRADED TO DRAINS SHOWN ON PLAN VIEW.
 - ALL CLEANOUTS SHALL BE 4" PIPE WITH A CLEANOUT AT THE END OF EACH LINE.

4\"/>

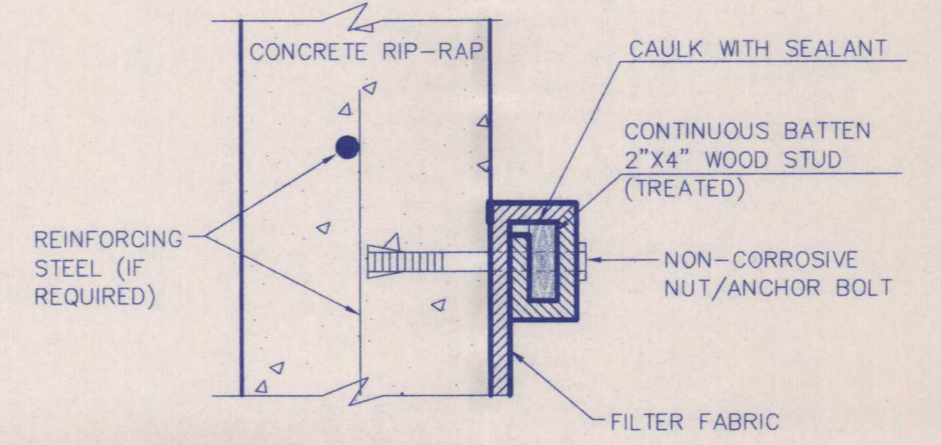

FILTER FABRIC ANCHORING DETAIL
N.T.S.

NOTE:
CONTRACTOR TO PLACE ANCHOR BOLTS AT 5'-0" O.C.

Date: Aug 20, 2002, 2:23pm User ID: esmmons
 File: P:\5129\02\DESIGN\CIVIL\B4529202-1.dwg

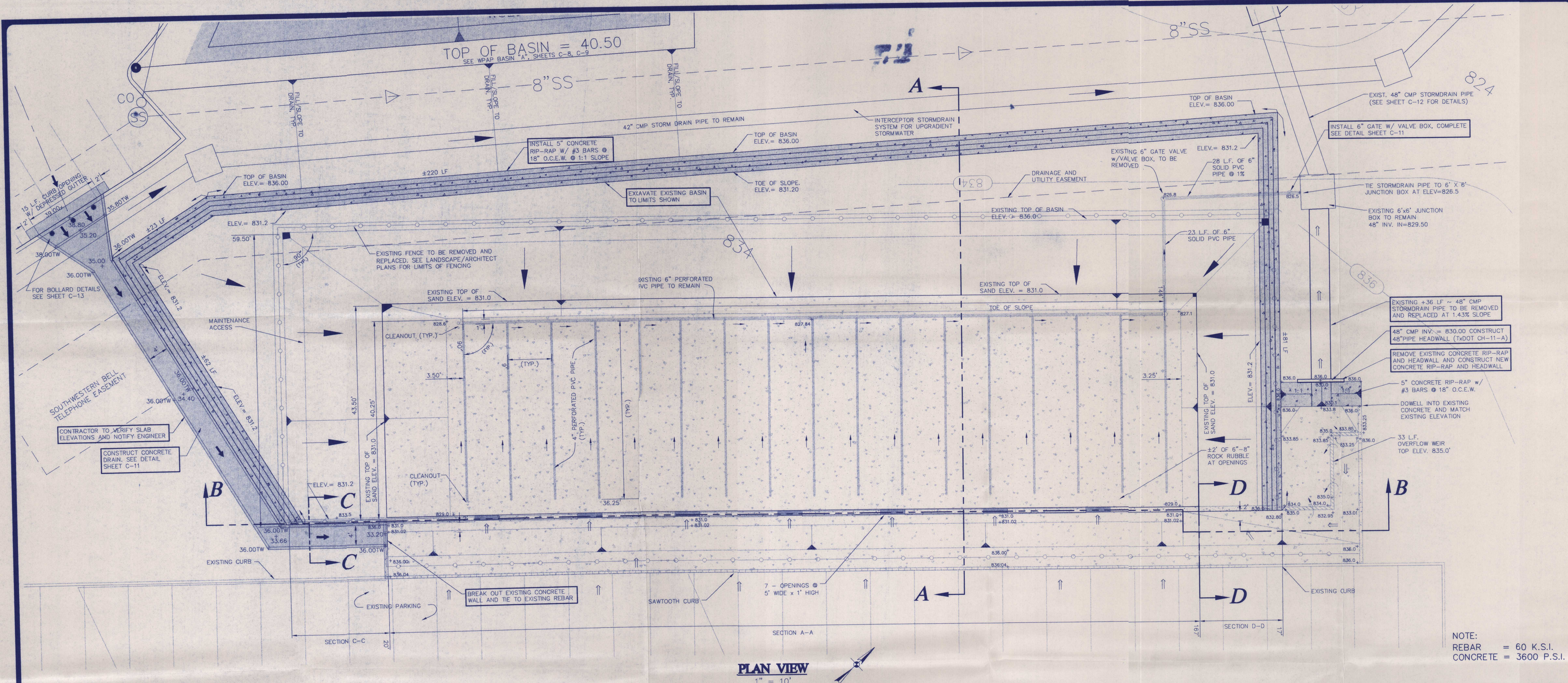

PLAN VIEW
 1" = 10'

NOTE:
 REBAR = 60 K.S.I.
 CONCRETE = 3600 P.S.I.

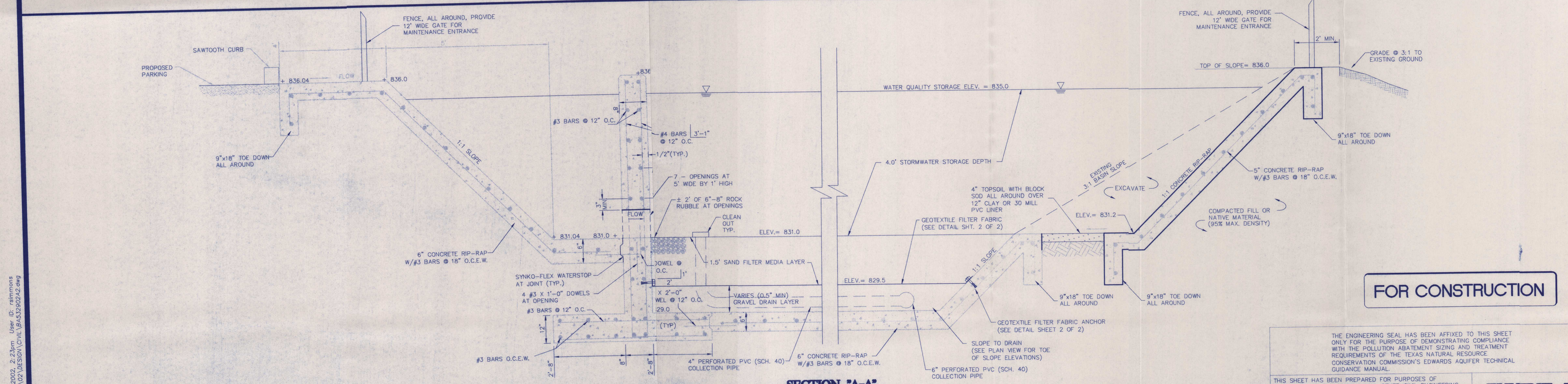

SECTION "A-A"
 N.T.S.

FOR CONSTRUCTION

THE ENGINEERING SEAL HAS BEEN AFFIXED TO THIS SHEET ONLY FOR THE PURPOSE OF DEMONSTRATING COMPLIANCE WITH THE POLLUTION ABATEMENT SIZING AND TREATMENT REQUIREMENTS OF THE TEXAS NATURAL RESOURCE CONSERVATION COMMISSION'S EDWARDS AQUIFER TECHNICAL GUIDANCE MANUAL.
 THIS SHEET HAS BEEN PREPARED FOR PURPOSES OF POLLUTION ABATEMENT ONLY. ALL OTHER CIVIL ENGINEERING RELATED INFORMATION SHOULD BE ACQUIRED FROM THE APPROPRIATE SHEET IN THE CIVIL IMPROVEMENT PLANS.

REVISIONS:
 3 5/31/02 BASIN MODIFICATION
 6/07/02- FOR CONSTRUCTION



PAPE-DAWSON ENGINEERS
 555 EAST RANNEY | SAN ANTONIO TEXAS 78216 | PHONE: 210.375.9000
 FAX: 210.375.9010

**HERITAGE BUSINESS PARK
 WATER POLLUTION ABATEMENT BASIN "B-1"**
 SHEET 1 OF 2

JOB NO. 5329.02
 DATE AUGUST 2002
 DESIGNER GS
 CHECKED GS DRAWN WJ
 SHEET C-10

EXHIBIT 5



PAPE-DAWSON ENGINEERS
 555 EAST RAMSEY | SAN ANTONIO TEXAS 78216 | PHONE: 210.375.9000
 FAX: 210.375.9010

**HERITAGE BUSINESS PARK
 WATER POLLUTION ABATEMENT BASIN "B-1"
 SHEET 2 OF 2**

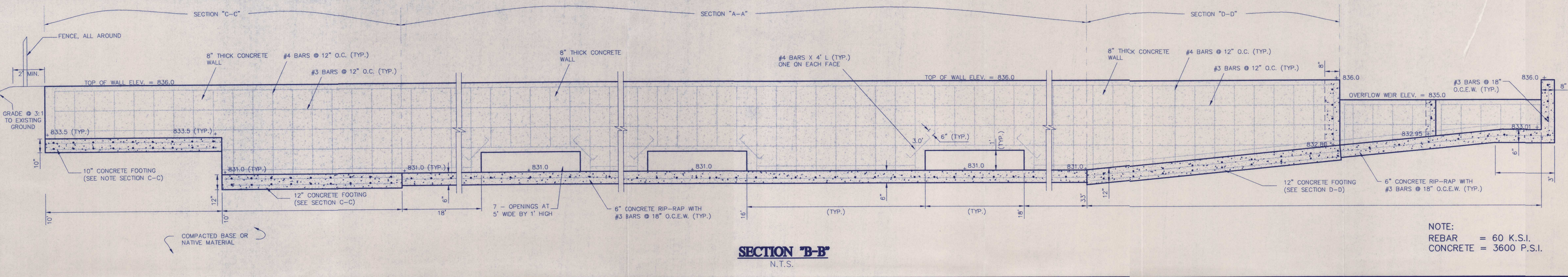

NOTE:
 REBAR = 60 K.S.I.
 CONCRETE = 3600 P.S.I.

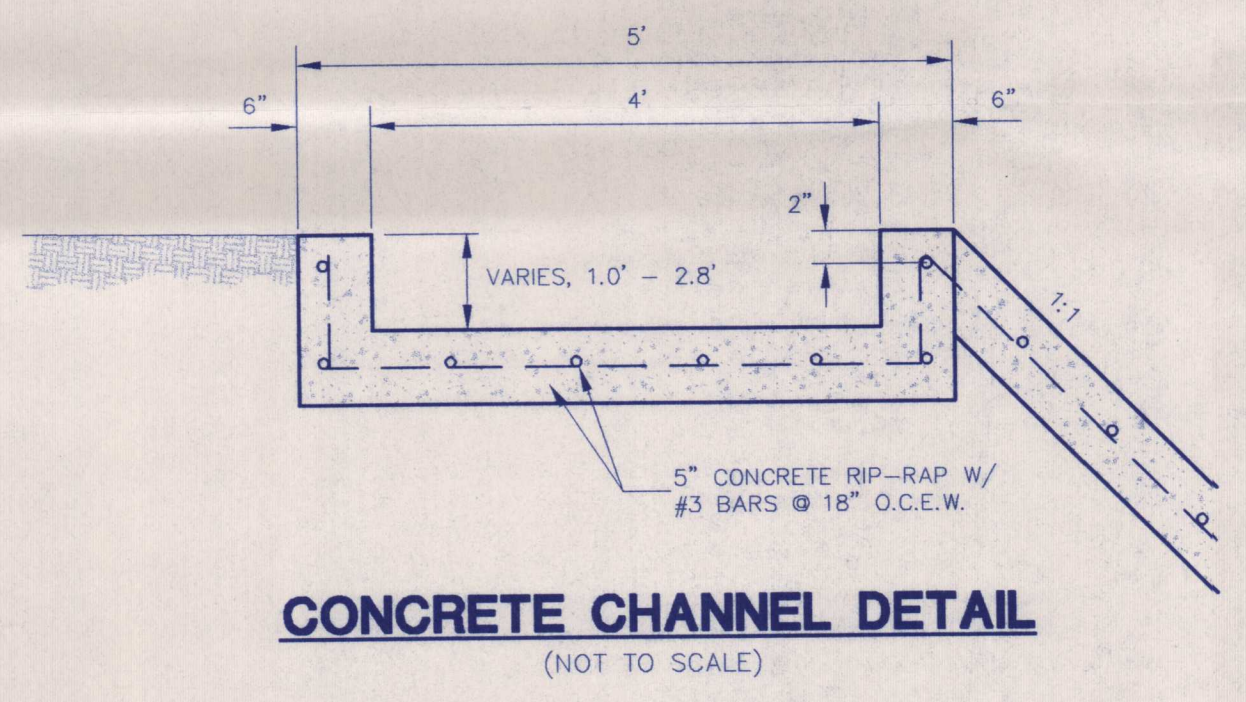
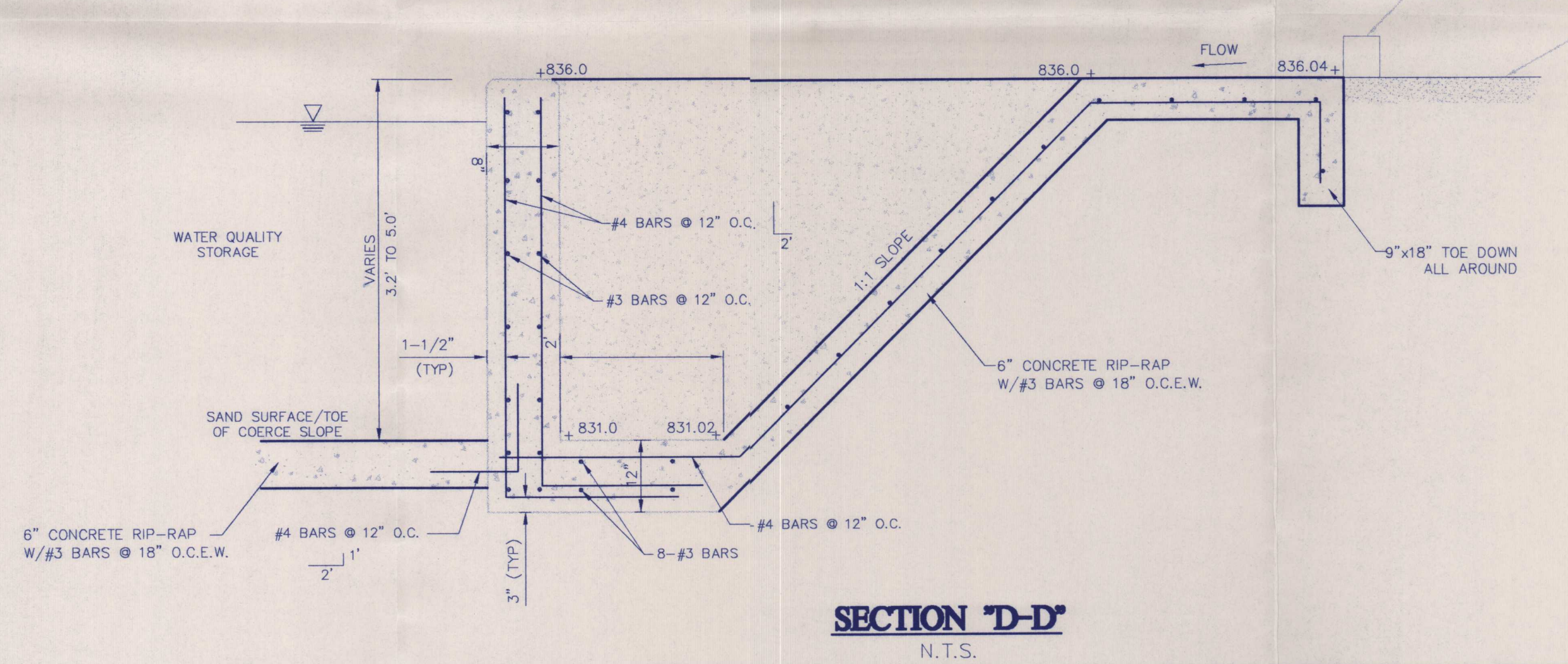
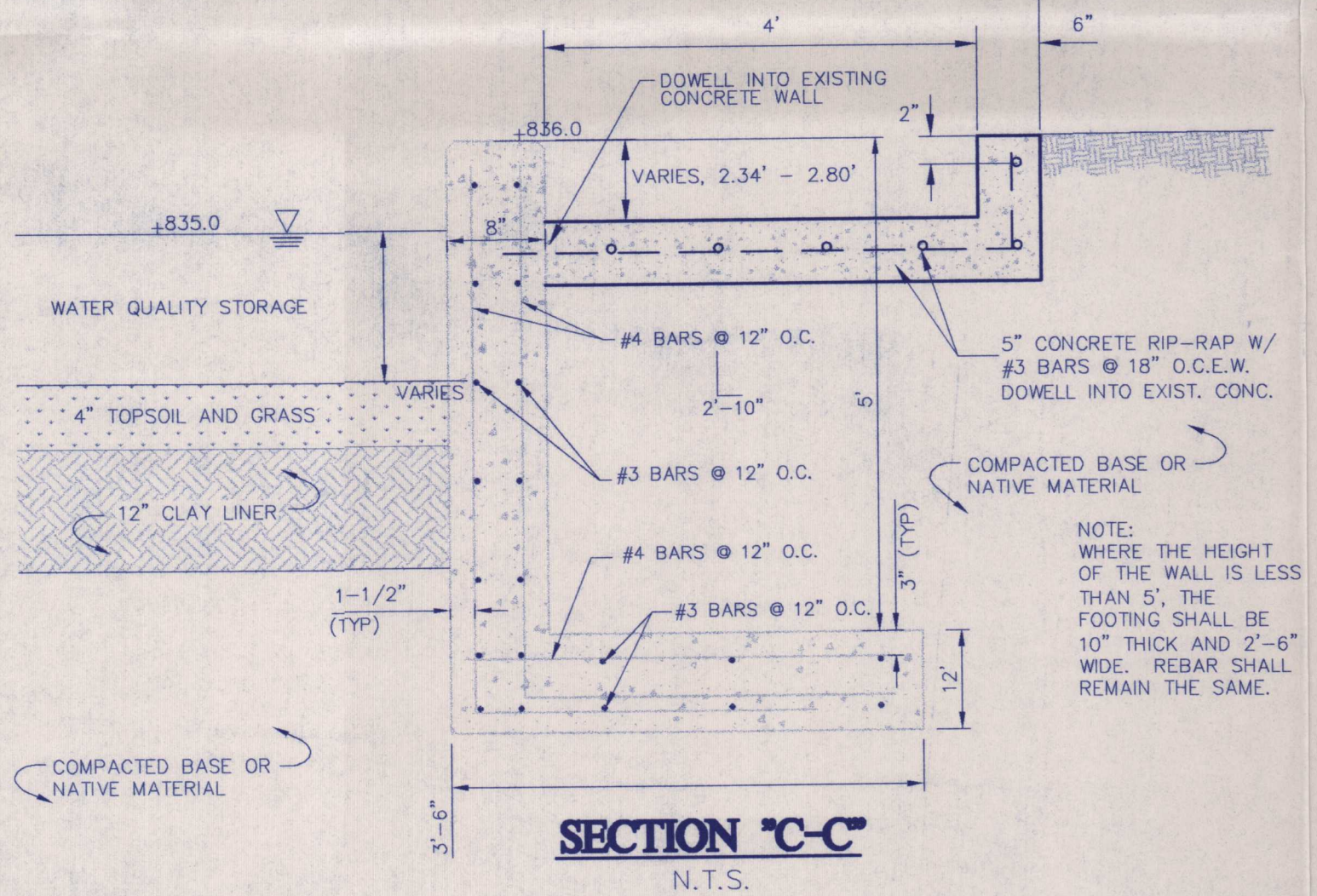

CONCRETE CHANNEL DETAIL
 (NOT TO SCALE)

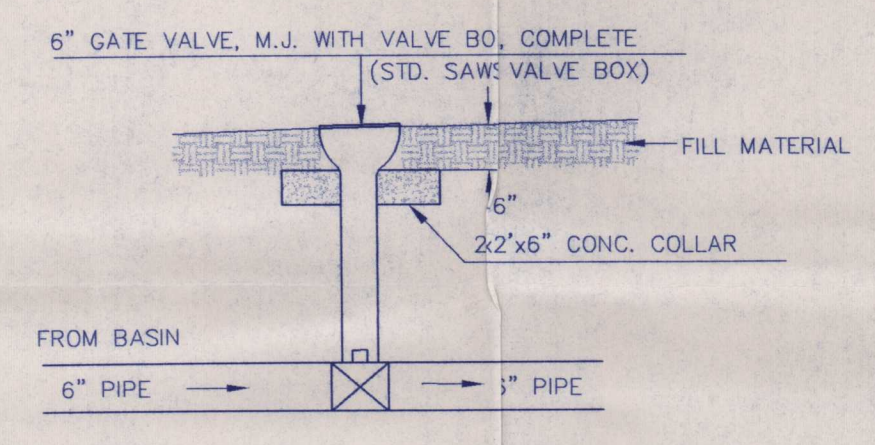

6 INCH GATE VALVE DETAIL
 N.T.S.

- NOTE:
1. VALVE WILL BE SET PARTIALLY CLOSED SO AS TO PROVIDE A MINIMUM DRAWDOWN TIME OF 24 HOURS.
 2. CONTRACTOR SHALL PROVIDE OWNER WITH VALVE OPERATING KEY/ROD PRIOR TO PROJECT COMPLETION.

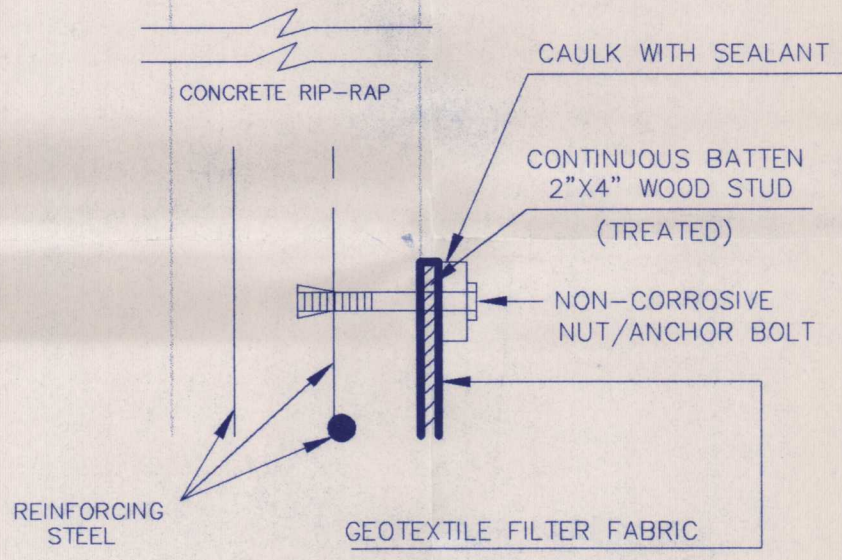

GEOTEXTILE FILTER FABRIC ANCHORING DETAIL
 N.T.S.

- NOTE:
 CONTRACTOR TO PLACE ANCHOR BOLTS AT 5'-0" O.C.

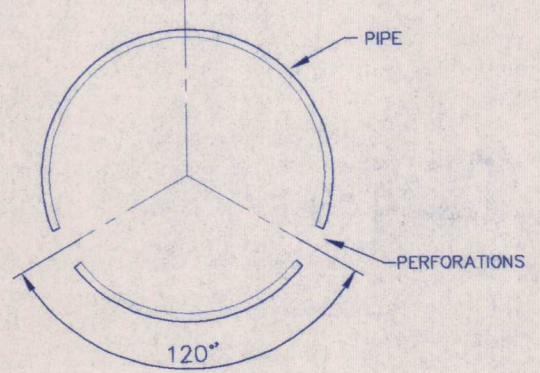

MINIMUM DIAMETER = 4"; SCHEDULE 40 PVC (SEE PLAN VIEW)
 THE MAXIMUM SPACING BETWEEN ROWS OF PERFORATIONS SHOULD NOT EXCEED 6".
 SET PERFORATIONS DOWN.

NOTE:
 PIPES SHOULD LIE FLAT ON CONCRETE BOTTOM WHICH HAS BEEN GRADED TO DRAIN AS SHOWN ON PLAN VIEW.

PERFORATED PIPE
 N.T.S.

CLAY LINER SPECIFICATIONS

PROPERTY	TEST METHOD	UNIT	SPECIFICATION
PERMEABILITY	ASTM D-2434	CM/SEC	1×10^{-15}
PLASTICITY INDEX OF CLAY	ASTM D-423 & D-42	%	NOT LESS THAN 15
LIQUID LIMIT OF CLAY	ASTM D-2216	%	NOT LESS THAN 30
CLAY PARTICLES PASSING	ASTM D-422	%	NOT LESS THAN 30
CLAY COMPACTION	ASTM D-2216	%	95% OF STANDARD PROCTOR DENSITY

THE CLAY LINER SHALL HAVE A MINIMUM THICKNESS OF TWELVE (12) INCHES.
 IF A GEOMEMBRANE LINER IS USED IT SHALL HAVE MINIMUM THICKNESS OF THIRTY (30) MILS. AND BE ULTRAVIOLET RESISTANT.

GEOTEXTILE FILTER FABRIC SPECIFICATIONS

THE SEPARATION LAYER SHALL BE A DRAINAGE MATTING CONSISTING OF NON-WOVEN GEOTEXTILE FABRIC MEETING THE FOLLOWING SPECIFICATIONS:

PROPERTY	TEST METHOD	SPECIFICATION
GEOTEXTILE FABRIC		
WEIGHT (OZ/SY)	ASTM D 3776	4.0
GRAB STRENGTH (LBS.)	ASTM D 4632	90
ELONGATIONS (%)	ASTM D 4632	55
PUNCTURE (LBS)	ASTM D 3787	60
AOS (SIEVE #)	ASTM D 4751	70-80
FLOW RATE (GPM/SF)	ASTM D 4491	120

FABRIC OVERLAP SHALL BE A MINIMUM OF 24".
 ALL OVERLAPS SHALL BE WIRE TIED AT A MAXIMUM OF 36" INTERVALS.

BASIN DESIGN DATA

WATERSHED AREA	=	537,254 (12.33AC)
RUN OFF DEPTH	=	0.90 INCH
REQUIRED CAPTURE VOLUME	=	48,133 CF
REQUIRED SAND AREA	=	5,157 SF
BASIN STORM WATER DEPTH	=	4 FT
BASIN CAPTURE VOLUME	=	62,398 CF
BASIN SAND AREA	=	7,264 SF

NOTE:
 SAND FILTER MATERIAL SHALL BE 0.0165" (#40 SIEVE) TO 0.0469" (#16 SIEVE) SILICA BASED WASHED SAND.
 ROCK FOR GRAVEL LAYER SHALL BE 1/2" TO 1" DIAMETER WASHED RIVER GRAVEL.

- NOTE:
1. CONTRACTOR IS ADVISED THAT TRC DOES NOT ALLOW CHANGES TO PERMANENT POLLUTION ABATEMENT MEASURES WITHOUT THEIR PRIOR APPROVAL.
 2. CONTRACTOR SHALL NOTIFY CERTIFYING ENGINEER WHEN BASIN CONSTRUCTION HAS PROCEEDED TO THE FOLLOWING MILESTONES:
 - a.) REINFORCING STEEL FOR BASIN WALL OR RIP-RAP LINER HAS BEEN SET, CONCRETE HAS NOT BEEN PLACED AND DRAIN PIPE IS IN PLACE.
 - b.) CONCRETE WALL AND RIP-RAP LINER IN PLACE AND UNDER DRAIN SYSTEM IS IN PLACE WITHOUT GRAVEL.
 - c.) GRAVEL AROUND UNDER DRAIN SYSTEM IS IN PLACE AND FILTER FABRIC IS INSTALLED AND ATTACHED TO WALLS OR RIP-RAP.
 - d.) SAND FILTER MEDIA HAS BEEN PLACED & BASIN HAS BEEN COMPLETELY FINISHED INCLUDING SOD OR SEED PLACEMENT ON SIDE SLOPES (WHERE APPLICABLE).
 3. WORK SHALL NOT CONTINUE ON THE BASIN UNTIL THE ENGINEER HAS HAD AN OPPORTUNITY TO OBSERVE THE STATUS OF CONSTRUCTION AT EACH STAGE. CONTRACTOR SHALL PROVIDE ENGINEER A MINIMUM OF 24 HOURS ADVANCE NOTICE PRIOR TO TIME THE BASIN WILL BE AT THE REQUIRED STAGE.
 4. BEFORE FINAL ACCEPTANCE OF CONSTRUCTION BY THE OWNER, THE CONTRACTOR WILL REMOVE ALL TRASH, DEBRIS, AND ACCUMULATED SILT FROM THE BASIN AND REESTABLISH THEM TO THE PROPER OPERATING CONDITION.
 5. THE MINIMUM DRAIN TIME FOR A FULL BASIN IS 24 HOURS. THE CONTRACTOR SHALL RESTRICT THE FLOW THROUGH ADJUSTING OF THE GATE VALVE ON THE DISCHARGE PIPE, SO AS TO PROVIDE THE MINIMUM 24 HOUR DRAW DOWN TIME.
 6. COMPRESSIVE STRENGTH OF CONCRETE SHALL BE 3600 P.S.I.
 YIELD OF STRENGTH OF REBAR SHALL BE 60 K.S.I.
 7. PROVIDE CORNER REBAR AT ALL HORIZONTAL BENDS AND TURNS WITH THE DIAMETER AND QUANTITY EQUAL TO THE DESIGNED HORIZONTAL REBAR.
 8. PROVIDE CONTINUOUS REBAR THROUGH ALL CROSS-SECTION TRANSITIONS.

FOR CONSTRUCTION

THE ENGINEERING SEAL HAS BEEN AFFIXED TO THIS SHEET ONLY FOR THE PURPOSE OF DEMONSTRATING COMPLIANCE WITH THE POLLUTION ABATEMENT SIZING AND TREATMENT REQUIREMENTS OF THE TEXAS NATURAL RESOURCE CONSERVATION COMMISSION'S EDWARDS AQUIFER TECHNICAL GUIDANCE MANUAL.

THIS SHEET HAS BEEN PREPARED FOR PURPOSES OF POLLUTION ABATEMENT ONLY. ALL OTHER CIVIL ENGINEERING RELATED INFORMATION SHOULD BE ACQUIRED FROM THE APPROPRIATE SHEET IN THE CIVIL IMPROVEMENT PLANS.

EXHIBIT 5

JOB NO. 5329.02
 DATE AUGUST 2002
 DESIGNER GS
 CHECKED GS DRAWN WJ
 SHEET C-11

BASIN DESIGN CRITERIA

POLLUTANT LOAD AND REMOVAL CALCULATIONS

(Complying with the Edwards Aquifer Rules: Technical Guidance on Best Management Practices, Section 3.3)

PROJECT NAME: Heritage Business Park - Revised Watershed
JOB NUMBER: 5329.01

DATE: August 19, 2002
WATERSHED: A
PAGE: 1 of 2

WATERSHED INFORMATION

	WATERSHED AREAS	Existing		Proposed	
		Sq. Ft.	Acres	Sq. Ft.	Acres
1.)	Total Watershed	219,050	5.03	219,050	5.03
2.)	Impervious Cover	0	0.00	197,145	4.53
	% Impervious Cover, I.C.	0.00%		90.00%	

3.) STORMWATER RUNOFF OF 25 YEAR STORM: $Q_{25} = 43.3$ cfs

4.) BACKGROUND LOAD CALCULATION:

5.) Enter (YES) for applicable BMP's:

$$L = P(A_u \times 0.54 + A_d \times R_v \times 38.4) \text{ Eqn 3.4}$$

$A_u = 5.03$ Area undeveloped (ac.)

$A_d = 0.00$ Area developed (ac.)

Total Area = 5.03 ac. **OK**

$$R_v = 0.546(IC)^2 + 0.328(IC) + 0.030 \text{ Eqn 3.2}$$

$R_v = 0.030$ Runoff coefficient

BACKGROUND LOAD = 89.61 lb/yr

GRASSY SWALES = NO

SAND FILTER BASIN = YES

VEGETATED FILTER STRIPS = NO

RETENTION BASIN = NO

6.) ANNUAL RAINFAL (inches/year) = 33

Per Table 3.2

COUNTY	AVE. ANNUAL PRECIPITATION	
Bexar	30	in/yr
Comal	33	in/yr
Medina	28	in/yr

I. ANNUAL POLLUTANT LOAD CALCULATIONS

$$L = (A)(P)(R_v)(C)(0.226) \text{ Eqn 3.1}$$

$$L = (A)(P)(R_v)(38.4) \text{ Eqn 3.3}$$

(L) = ANNUAL POLLUTANT LOAD, lbs.

(A) = AREA, acres

(P) = AVE. ANNUAL PRECIPITATION (in./yr (30 for Bexar County))

(R_v) = RUNOFF/RAINFALL RATIO (i.e., $0.546(IC)^2 + 0.328(IC) + 0.030$)
 (0.226) = CONVERSION FACTOR

(C) = POLLUTANT CONCENTRATION, 170 mg/L

(L) = SEE CHART ON FOLLOWING PAGE

(A) = 5.03 acres

(RF) = 33 in/yr

(R_v) = 0.767

ANNUAL POLLUTANT LOAD = 4,890.53 lb/yr

POLLUTANT LOADING RESULTS

	EXISTING (Eqn 3.4)	PROPOSED (Eqn 3.3)	INCREASE:	80% TARGET REMOVAL
L (TSS)	89.61	4,890.53	4,800.92	3,840.74

II. TNRCC TECHNICAL GUIDANCE MANUAL TSS REMOVAL RATE EFFICIENCIES

Grassy Swales 70%	Vegetated Filter Strip 85%	Sand Filter Basin 89%	Retention Basin 100%
----------------------	-------------------------------	--------------------------	-------------------------

III. FRACTION OF LOAD CAPTURED FOR OFFLINE BMP'S

$L_R = L_1 \times F \times \text{Fraction of site treated} \times (\text{TSS Removal Efficiency})$ Eqn 3.6

L_R = Load Removed (lbs.)

L_1 = Post development load for the entire site (lbs.)

F = Fraction of load capture by BMP

F = 0.88

Per Table 3.3 BMP Design Capture Volume(%)

DEPTH	20%	30%	40%	50%	60%	70%	80%	90%	100%
0	0	0	0	0	0	0	0	0	0
0.1	57	49	45	40	33	25	21	17	9
0.3	90	79	75	70	61	53	48	43	34
0.5	100	98	92	87	83	78	73	68	64
0.75		100	98	95	91	87	85	82	79
1			100	100	97	93	90	86	83
1.5					100	100	96	92	88
2							100	95	93
3								100	98
4									100

Runoff depth (estimated from above): 1.19 in

IV. CAPTURE VOLUME REQUIRED

A_D = 5.03 Drainage area (acres)

H = 1.19 Runoff depth (in)

Vol. = 25,995 Capture Volume includes 20% for sediment accumulation

V. SAND AREA REQUIRED

d = 5 Depth of Water (ft)

Af = 2,437 Sand Area Required (sf) = (Vol.)*(L) / (k(h+L)t)

POLLUTANT LOAD AND REMOVAL CALCULATIONS

(Complying with the Edwards Aquifer Rules: Technical Guidance on Best Management Practices, Section 3.3)

PROJECT NAME: Oak Run Commercial Unit 9 - Revised Watershed
JOB NUMBER: 5123-04

DATE: August 19, 2002
WATERSHED: B-1
PAGE: 1 of 2

WATERSHED INFORMATION

	WATERSHED AREAS	Existing		Proposed	
		Sq. Ft.	Acres	Sq. Ft.	Acres
1.)	Total Watershed	537,095	12.33	537,095	12.33
2.)	Impervious Cover	0	0.00	456,531	10.48
	% Impervious Cover, I.C.	0.00%		85.00%	

3.) STORMWATER RUNOFF OF 25 YEAR STORM: $Q_{25} = 88.8$ cfs

4.) BACKGROUND LOAD CALCULATION:

5.) Enter (YES) for applicable BMP's:

$$L = P(A_u \times 0.54 + A_d \times R_v \times 38.4) \text{ Eqn 3.4}$$

$A_u = 12.33$ Area undeveloped (ac.)

$A_d = 0.00$ Area developed (ac.)

Total Area = 12.33 ac. **OK**

$$R_v = 0.546(IC)^2 + 0.328(IC) + 0.030 \text{ Eqn 3.2}$$

$R_v = 0.030$ Runoff coefficient

BACKGROUND LOAD = 219.72 lb/yr

GRASSY SWALES = NO

SAND FILTER BASIN = YES

VEGETATED FILTER STRIPS = NO

RETENTION BASIN = NO

6.) ANNUAL RAINFAL (inches/year) = 33

Per Table 3.2

COUNTY	AVE. ANNUAL PRECIPITATION	
Bexar	30	in/yr
Comal	33	in/yr
Medina	28	in/yr

I. ANNUAL POLLUTANT LOAD CALCULATIONS

$$L = (A)(P)(R_v)(C)(0.226) \text{ Eqn 3.1}$$

$$L = (A)(P)(R_v)(38.4) \text{ Eqn 3.3}$$

(L) = ANNUAL POLLUTANT LOAD, lbs.

(A) = AREA, acres

(P) = AVE. ANNUAL PRECIPITATION (in./yr (30 for Bexar County)

(Rv) = RUNOFF/RAINFALL RATIO (i.e., $0.546(IC)^2 + 0.328(IC) + 0.030$)

(0.226) = CONVERSION FACTOR

(C) = POLLUTANT CONCENTRATION, 170 mg/L

(L) = SEE CHART ON FOLLOWING PAGE

(A) = 12.33 acres

(RF) = 33 in/yr

(Rv) = 0.703

ANNUAL POLLUTANT LOAD = 10,988.53 lb/yr

POLLUTANT LOADING RESULTS

	EXISTING (Eqn 3.4)	PROPOSED (Eqn 3.3)	INCREASE:	TARGET REMOVAL
L (TSS)	219.72	10,988.53	10,768.81	80% 8,615.05

II. TNRCC TECHNICAL GUIDANCE MANUAL TSS REMOVAL RATE EFFICIENCIES

Grassy Swales	Vegetated Filter Strip	Sand Filter Basin	Retention Basin
70%	85%	89%	100%

III. FRACTION OF LOAD CAPTURED FOR OFFLINE BMP'S

$L_R = L_1 \times F \times \text{Fraction of site treated} \times (\text{TSS Removal Efficiency}) \text{ Eqn 3.6}$

L_R = Load Removed (lbs.)

L_1 = Post development load for the entire site (lbs.)

F = Fraction of load capture by BMP

F = 0.88

Per Table 3.3 BMP Design Capture Volume(%)

DEPTH	20%	30%	40%	50%	60%	70%	80%	90%	100%
0	0	0	0	0	0	0	0	0	0
0.1	57	49	45	40	33	25	21	17	9
0.3	90	79	75	70	61	53	48	43	34
0.5	100	98	92	87	83	78	73	68	64
0.75		100	98	95	91	87	85	82	79
1			100	100	97	93	90	86	83
1.5					100	100	96	92	88
2							100	95	93
3								100	98
4									100

Runoff depth (estimated from above): 1.04 in

IV. CAPTURE VOLUME REQUIRED

A_D = 12.33 Drainage area (acres)

H = 1.04 Runoff depth (in)

Vol. = 55,823 Capture Volume includes 20% for sediment accumulation

V. SAND AREA REQUIRED

d = 4 Depth of Water (ft)

A_f = 5,981 Sand Area Required (sf) = (Vol.)*(L) / (k(h+L)t)

Robert J. Huston, *Chairman*
R. B. "Ralph" Marquez, *Commissioner*
Kathleen Hartnett White, *Commissioner*
Jeffrey A. Saitas, *Executive Director*

TEXAS NATURAL RESOURCE CONSERVATION COMMISSION

Protecting Texas by Reducing and Preventing Pollution

May 8, 2002

Mr. Robert L. Worth, Jr.
R. L. Worth & Associates
4040 Broadway, Suite 552
San Antonio, TX 78216

Re: Edwards Aquifer, Comal County
NAME OF PROJECT: Heritage Business Park; Located on the northwest side of Independence Drive; New Braunfels, Texas
TYPE OF PLAN: Request for Approval of a Water Pollution Abatement Plan (WPAP); 30 Texas Administrative Code (TAC) Chapter 213 Edwards Aquifer
Edwards Aquifer Protection Program File No. 1814.00

Dear Mr. Worth:

The Texas Natural Resource Conservation Commission (TNRCC) has completed its review of the WPAP application for the referenced project submitted to the San Antonio Regional Office by Cara C. Tackett, P.E., of Pape-Dawson Engineers, Inc. on behalf of R. L. Worth & Associates on February 13, 2002. As presented to the TNRCC, the Temporary and Permanent Best Management Practices (BMPs) and construction plans were prepared by a Texas Licensed Professional Engineer to be in general compliance with the requirements of 30 TAC Chapter 213. These planning materials were sealed, signed, and dated by a Texas Licensed Professional Engineer. Therefore, based on the engineer's concurrence of compliance, the planning materials for construction of the proposed project and pollution abatement measures are hereby approved subject to applicable state rules and the conditions in this letter. The applicant or a person affected may file with the chief clerk a motion for reconsideration of the executive director's final action on this Edwards Aquifer protection plan. A motion for reconsideration must be filed no later than 20 days after the date of this approval letter. *This approval expires two (2) years from the date of this letter unless, prior to the expiration date, more than 10 percent of the construction has commenced on the project or an extension of time has been requested.*

PROJECT DESCRIPTION

The proposed commercial project will have an area of approximately 10.4 acres. It will include the construction of a single story, 90,380 square foot office building and associated parking. The impervious cover will be 6.55 acres (63.0 percent). Project wastewater will be disposed of by conveyance to the existing New Braunfels Utilities Water Recycling Center owned by the New Braunfels Utilities.

Mr. Robert L. Worth
Page 2
May 8, 2002

PERMANENT POLLUTION ABATEMENT MEASURES

A modified partial sedimentation filtration basin designed using the TNRCC technical guidance document, *Complying with the Edwards Aquifer Rules: Technical Guidance on Best Management Practices* (June 1999) will be constructed to treat storm water runoff. The basin is designed to provide treatment for 7.71 acres (6.55 acres of the impervious cover) with capture volume of 35,485 cubic feet and a sand filter area of 4,125 square feet. The approved measures have been presented to meet the required 80 percent removal of the increased load in total suspended solids caused by the project.

GEOLOGY

According to the geologic assessment included with the application, three geologic features were identified on the site. The San Antonio Regional Office site inspection of April 24, 2002, revealed that regulated activities have occurred on the site.

SPECIAL CONDITIONS

- I. All permanent pollution abatement measures shall be operational prior to use of any of the facilities.
- II. All sediment and or media removed from the sedimentation/filtration basins during maintenance activities shall be properly disposed of according to 30 TAC 330 or 30 TAC 335 as applicable.
- III. A sediment depth marker, as described in *Complying with the Edwards Aquifer Rules: Technical Guidance on Best Management Practices* (June 1999), must be installed in the sedimentation/filtration basin.
- IV. During the April 24, 2002, site assessment investigation of the project site, cleared and disturbed areas were observed. This construction was conducted without the prior approval of the water pollution abatement plan as required by Commission rules (30 TAC Chapter 213). Therefore, the applicant is hereby advised that the after-the-fact approval of the development, as provided by this letter, shall not absolve the applicant of any prior violations of Commission rules related to this project, and shall not necessarily preclude the Commission from pursuing appropriate enforcement actions and administrative penalties associated with such violations, as provided in 30 TAC §213.10 of Commission rules.

STANDARD CONDITIONS

1. Pursuant to §26.136 of the Texas Water Code, any violations of the requirements in 30 TAC Chapter 213 may result in administrative penalties.

Prior to Commencement of Construction:

2. Within 60 days of receiving written approval of an Edwards Aquifer protection plan, the applicant must submit to the San Antonio Regional Office, proof of recordation of notice in the county deed records, with the volume and page number(s) of the county deed records of the county in which the

property is located. A description of the property boundaries shall be included in the deed recordation in the county deed records. A suggested form (Deed Recordation Affidavit, TNRCC-0625) that you may use to deed record the approved WPAP is enclosed.

3. All contractors conducting regulated activities at the referenced project location shall be provided a copy of this notice of approval. At least one complete copy of the approved WPAP and this notice of approval shall be maintained at the project location until all regulated activities are completed.
4. Modification to the activities described in the referenced WPAP application following the date of approval may require the submittal of a plan to modify this approval, including the payment of appropriate fees and all information necessary for its review and approval prior to initiating construction of the modifications.
5. The applicant must provide written notification of intent to commence construction, replacement, or rehabilitation of the referenced project. Notification must be submitted to the San Antonio Regional Office no later than 48 hours prior to commencement of the regulated activity. Written notification must include the date on which the regulated activity will commence, the name of the approved plan and file number for the regulated activity, and the name of the prime contractor with the name and telephone number of the contact person. The executive director will use the notification to determine if the approved plan is eligible for an extension.
6. Temporary erosion and sedimentation (E&S) controls, i.e., silt fences, rock berms, stabilized construction entrances, or other controls described in the approved WPAP, must be installed prior to construction and maintained during construction. Temporary E&S controls may be removed when vegetation is established and the construction area is stabilized. If a water quality pond is proposed, it shall be used as a sedimentation basin during construction. The TNRCC may monitor stormwater discharges from the site to evaluate the adequacy of temporary E&S control measures. Additional controls may be necessary if excessive solids are being discharged from the site.
7. All borings with depths greater than or equal to 20 feet must be plugged with non-shrink grout from the bottom of the hole to within three (3) feet of the surface. The remainder of the hole must be backfilled with cuttings from the boring. All borings less than 20 feet must be backfilled with cuttings from the boring. All borings must be backfilled or plugged within four (4) days of completion of the drilling operation. Voids may be filled with gravel.

During Construction:

8. During the course of regulated activities related to this project, the applicant or agent shall comply with all applicable provisions of 30 TAC Chapter 213, Edwards Aquifer. The applicant shall remain responsible for the provisions and conditions of this approval until such responsibility is legally transferred to another person or entity.
9. If any sensitive feature (caves, solution cavities, sink holes, etc.) is discovered during construction, all regulated activities near the feature must be suspended immediately. The applicant or his agent must immediately notify the San Antonio Regional Office of the discovery of the feature. Regulated

Mr. Robert L. Worth
Page 4
May 8, 2002

activities near the feature may not proceed until the executive director has reviewed and approved the methods proposed to protect the feature and the aquifer from potentially adverse impacts to water quality. The plan must be sealed, signed, and dated by a Texas Licensed Professional Engineer.

10. No wells exist on the site. All water wells, including injection, dewatering, and monitoring wells must be in compliance with the requirements of the Texas Department of Licensing and Regulation under Title 16 TAC Chapter 76 (relating to Water Well Drillers and Pump Installers) and all other locally applicable rules, as appropriate.
11. If sediment escapes the construction site, the sediment must be removed at a frequency sufficient to minimize offsite impacts to water quality (e.g., fugitive sediment in street being washed into surface streams or sensitive features by the next rain). Sediment must be removed from sediment traps or sedimentation ponds not later than when design capacity has been reduced by 50 percent. Litter, construction debris, and construction chemicals shall be prevented from becoming stormwater discharge pollutants.
12. The following records shall be maintained and made available to the executive director upon request: the dates when major grading activities occur, the dates when construction activities temporarily or permanently cease on a portion of the site, and the dates when stabilization measures are initiated.
13. Stabilization measures shall be initiated as soon as practicable in portions of the site where construction activities have temporarily or permanently ceased, and construction activities will not resume within 21 days. When the initiation of stabilization measures by the 14th day is precluded by weather conditions, stabilization measures shall be initiated as soon as practicable.

After Completion of Construction:

14. A Texas Licensed Professional Engineer must certify in writing that the permanent BMPs or measures were constructed as designed. The certification letter must be submitted to the San Antonio Regional Office within 30 days of site completion.
15. The applicant shall be responsible for maintaining the permanent BMPs after construction until such time as the maintenance obligation is either assumed in writing by another entity having ownership or control of the property (such as without limitation, an owner's association, a new property owner or lessee, a district, or municipality) or the ownership of the property is transferred to the entity. The regulated entity shall then be responsible for maintenance until another entity assumes such obligations in writing or ownership is transferred. A copy of the transfer of responsibility must be filed with the executive director through the San Antonio Regional Office within 30 days of the transfer. A copy of the transfer form (TNRCC-10263) is enclosed.
16. Upon legal transfer of this property, the new owner(s) is required to comply with all terms of the approved Edwards Aquifer protection plan. If the new owner intends to commence any new regulated activity on the site, a new Edwards Aquifer protection plan that specifically addresses the new activity must be submitted to the executive director. Approval of the plan for the new regulated activity by the executive director is required prior to commencement of the new regulated activity.

Mr. Robert L. Worth
Page 5
May 8, 2002

17. An Edwards Aquifer protection plan approval or extension will expire and no extension will be granted if more than 50 percent of the total construction has not been completed within ten years from the initial approval of a plan. A new Edwards Aquifer protection plan must be submitted to the San Antonio Regional Office with the appropriate fees for review and approval by the executive director prior to commencing any additional regulated activities.
18. At project locations where construction is initiated and abandoned, or not completed, the site shall be returned to a condition such that the aquifer is protected from potential contamination.

If you have any questions or require additional information, please contact Lynn M. Bumgardner of the Edwards Aquifer Protection Program of the San Antonio Regional Office at (210) 403-4023.

Sincerely,



for Jeffrey A. Saitas, P.E.
Executive Director
Texas Natural Resource Conservation Commission

JAS/LMB/eg

Enclosure: Deed Recordation Affidavit, Form TNRCC-0625
Change in Responsibility for Maintenance on Permanent BMPs-Form TNRCC-10263

cc: Ms. Cara C. Tackett, P.E., Pape-Dawson Engineers, Inc.
Mr. Michael Short, P.E., City of New Braunfels
Mr. Tom Hornseth, Comal County
Mr. Greg Ellis, Edwards Aquifer Authority
TNRCC Field Operations